

CATALOGUE 2022



SOLUTIONS FOR TIMBER DECKING AND CLADDING

www.novlek.com

We believe in manufacturing simple, high-performance, effective products, using carefully chosen, top-quality materials.

We believe in local manufacturing and purchasing, and we respect and work closely with our employees and collaborators.

We design and develop our own products, down to the last detail. We test them in the laboratory and in the field, because we believe they must be approved by their users.

We believe in telling the truth, so we only use photos of original projects created with our products. For the most part, we have overseen them on site, and we can talk about them.

We believe in questioning certainties and habits, in innovating and improving constantly, in sharing our knowledge and experience for a better quality of life and of work.

We believe in the importance of having happy customers and users, proud of our products, as we are, and in giving them an impeccable welcome and standard of service.

We believe that nothing can be taken for granted, and that every day we must deserve the trust our clients and users of our products place in us.

So we say, 'Thank you' to them!



FIX, PROTECT, INSULATE, INSTALL

We develop and manufacture ingenious, simple and effective solutions to fix, protect, insulate and install wooden boards and supports for your decks, cladding and other outdoor structures.

TABLE OF CONTENTS

Fasteners and connectors

NF DTU 51.4 assessments and validations	8
A solution for every type of timber and board profile	10
Installation using standard boards and local grooving	12
HardWood Clip®	15
SoftWood Clip™	33
Roots	43
Square Clip™	55
SPAX® screws	62

Protection and shimming

Bituminous strips	68
Ventilation shims	72
Isolation shims	76

Installation tools

Spacers	82
Step drill bits for wooden plugs	88
Drill countersinks for decking	92
Board clamp	96

Finishing products

Wooden plugs	102
--------------	-----

Merchandising and POS

Planograms	110
Display units and points of sale	112





Fasteners and connectors



HIDDEN FASTENERS

NF DTU 51.4 ASSESSMENTS AND VALIDATIONS

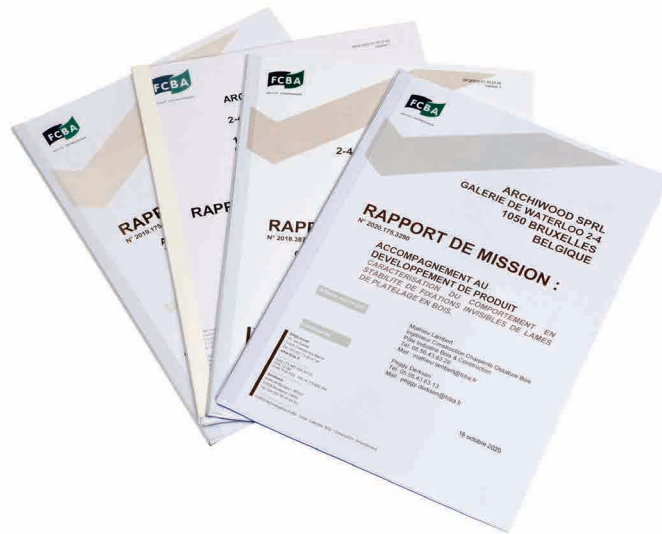

Constructing a wooden deck is not for novices

Located outdoors, often exposed to extreme hygrothermal variations, made up of boards with their own particular characteristics and properties, laid horizontally and close to the ground, decking is subject to stresses and strains that cannot be compared with any other wooden construction project.

Under these particularly demanding conditions, fixing the boards of a wooden deck to its substructure requires high-performance fasteners capable of withstanding all the stresses to which they will be subjected during their lifetime.

Under the NF DTU 51.4 standard, the fasteners used to secure the boards to the joists must be able to withstand a minimum withdrawal force of **50 daN per fastening point (i.e. 100 daN over the width of the board)**, whilst also demonstrating that the board/fastening/joist system remains stable when subjected to extreme variations in humidity and temperature.

As NF DTU 51.4 does not deal with hidden fasteners for decking boards (see insert "What are NF DTUs?"), since 2009 NÖVLEK® has entrusted the experts at FCBA with validating the compliance of its hidden fastening systems based on the requirements of that standard.

The technical evaluation process conducted by FCBA puts products through long, rigorous and extremely demanding testing.

It comprises two successive stages:

- **Withdrawal tests:** the assemblies tested with the fasteners being validated are subjected to a withdrawal force until they fail. They must demonstrate a satisfactory withdrawal resistance satisfying the requirement stipulated in NF DTU 51.4, i.e. with a characteristic value greater than 100 daN.
- **Stability behaviour tests:** the tests carried out in the physics laboratory consist of subjecting one or more decking models (based on the combinations of boards/joists/fixings being tested) to the successive effects of a very high level of humidification (continuous spraying of water on the upper surface for two weeks beyond the saturation point of the wood fibres) and extreme drying at 80°C (to reach an equilibrium humidity of 2-3%), and to study the behaviour of the boards in terms of stability by measuring certain deformation parameters: gaps between boards, variations in gaps between boards, differences in level between boards, cupping, flatness. The results are compared with the requirements stipulated in the NF DTU 51.4 and NF B 54-040 standards for outdoor timber decking.



MECHANICAL AND STABILITY TESTING AT FCBA

The laboratory tests carried out by FCBA are the equivalent of crash tests carried out in the automotive sector. Their sole purpose is to test the strength of the fasteners and to assess their stability behaviour when the decking is subjected to extreme loads or conditions, which it is unlikely to be exposed to in real life.



Withdrawal tests

The tests are designed to determine the maximum force needed to cause the assemblies to fail. They are performed on a vertical electromechanical testing machine. Numerous tests are carried out to determine a characteristic value.



Model for stability testing

Measurements are taken on the top of the decking using a large number of reference points positioned along lines, as shown in the photo above. Stability testing starts with the spraying stage and is followed by drying.

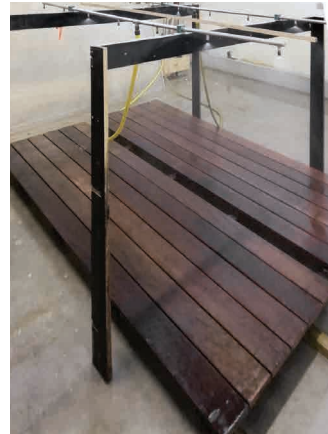

System for spraying the upper surface of the decking

Water is continuously sprayed onto the upper surface of the decking boards (2 litres/min./m²) for two weeks to simulate a prolonged period of rain and to soak the timber until its moisture content is greater than its fibre saturation point (i.e. above 30% moisture content).



Rapid drying at 80°C

After wetting the decking, the top side of the boards is dried by infrared radiation at a temperature of about 80°C, which very rapidly reduces the moisture content of the timber to only 2-3%.

DTU 51.4 LOGO



The NF DTU 51.4 logo, opposite, was created by NÖVLEK® in 2010 to mark and identify products that have been assessed, characterized and validated as compliant with the requirements of the NF DTU 51.4 standard, for which FCBA has issued a Technical File. When the logo is affixed to a product, it is always supported by the references in the FCBA Technical File.

To date, NÖVLEK® is the world's only manufacturer in this product category to have received six FCBA technical assessments and validations qualifying its HardWood Clip® and Roots fasteners as compliant with the requirements of NF DTU 51.4 for fastening decking boards. You will find them throughout the pages of this catalogue.

Beware of “conforms to DTU 51.4” statements

Since the publication of the first version of the NF DTU 51.4 standard in 2010, some unscrupulous manufacturers and suppliers have been claiming that their hidden fasteners or other products designed for use in the construction of timber decking comply with DTU 51.4. In the majority of cases, these products have never actually been assessed by an approved and independent laboratory such as the ones run by FCBA or CSTB. Some of them have only been partially tested (only mechanical tests), which is not enough to declare them compliant. In order to be certain of a product's compliance, demand to see the evaluation file from an approved laboratory and its conclusions, the only real proof of testing and validation of the product in respect of the requirements of the NF DTU 51.4 standard.

WHAT ARE NF DTU STANDARDS?

Extracts from the NF DTU Editor's Manual, DG-100, 10/01/2017

The DTU sets out specifications which the contractor needs to follow in order to produce work that meets the client's expectations in terms of stability, use and durability. It **conveys acknowledged and successful experience** and explains how to achieve optimum results. The DTU does not set out how to meet the regulatory requirements. It draws on the experience of professionals. **It does not deal with innovative techniques or applications** (e.g. processes that are under Technical Appraisal) or ones that are confidential and therefore not widely used.

The DTU cannot prohibit certain techniques or situations; it does not address or deal with them.

The DTU is dedicated to the implementation of technical solutions commonly used by most companies and unlike a catalogue, **does not aim to show all the solutions available on the market, in particular the innovative solutions that are subject to a specific technical assessment. Assessments such as the Technical Appraisal or the Technical Application Document (TAD) allow the validation of the implementation of products and processes that are not defined in NF DTU.**

HIDDEN FASTENERS



A SOLUTION FOR EVERY TYPE OF TIMBER AND BOARD PROFILE



NÖVLEK® offers a wide range of hidden fastening systems for decking boards, providing a suitable solution for every type of profile (solid or grooved edges) and a wide range of wood species used for decking.



Each solution has been developed to match perfectly the properties and specific behaviour of the species for which it has been designed and to meet the requirements of NF DTU 51.4. Each offers its own particular advantages, the details of which can be found in the following pages of this catalogue.

Whatever the wood species or profile of the boards, the requirements of NF DTU 51.4 and NF B 54-040 must be scrupulously respected, as must the installation instructions supplied with NÖVLEK® fasteners.

TROPICAL SPECIES						
Board profile Acceptable board width						
	Stable (S)	Moderately stable (MS)	Unstable (PS)	Stable (S)	Moderately stable (MS)	Unstable (PS)
< 140 mm	HardWood Clip <i>complies with DTU 51.4²</i>	HardWood Clip <i>complies with DTU 51.4²</i>	✘	HardWood Clip + local grooving¹ <i>complies with DTU 51.4²</i>	HardWood Clip + local grooving¹ <i>complies with DTU 51.4²</i>	✘
140 - 145 mm	HardWood Clip <i>complies with DTU 51.4²</i>	HardWood Clip <i>complies with DTU 51.4²</i>	✘	Roots <i>complies with DTU 51.4³</i>	Roots <i>complies with DTU 51.4³</i>	✘
				HardWood Clip + local grooving¹ <i>conforme DTU 51.4²</i>	HardWood Clip + local grooving¹ <i>complies with DTU 51.4²</i>	



The use of HardWood Clip® fasteners with certain tropical species such as Bilinga, Bangkirai, Yellow Cumaru, Tali, etc. that the NF B 54-040 standard classifies as moderately stable (MS) must be studied on a case-by-case basis, as special attention is required, in particular because of the problems that their properties could create.

The use of hidden fasteners is **not recommended** with tropical wood species that the NF B 54-040 standard classifies as unstable (PS) due to their particular physical properties and lack of stability, especially when drying out.



TEMPERATE HARDWOODS				
Board profile Acceptable board width				
	Moderately stable (MS)	Unstable (PS)	Moderately stable (MS)	Unstable (PS)
≤ 110 mm	HardWood Clip <i>complies with DTU 51.4⁴</i>	✘	HardWood Clip + local grooving¹ <i>complies with DTU 51.4⁴</i>	✘

Hidden fasteners should not be used with boards made of temperate hardwoods which the NF B 54-040 standard classifies as unstable (PS) (e.g. Robinia), due to their particular physical properties and lack of stability, especially when drying out. For a perfect result with boards made of moderately stable hardwoods (MS), a width of 90 mm is preferable.

1. Requires local grooving with a biscuit joiner (Lamello® type) | 2. FCBA tests: FCBA-2010.461.1263 | 3. FCBA tests: FCBA-2019.175.2230 and FCBA-2010.175.3290 | 4. FCBA tests: FCBA-2018.387.1177 | 5. FCBA tests: FCBA-DT 2016.511.2348

SOFTWOOD SPECIES (EXCLUDING THERMO-MODIFIED)		
Board profile		
Acceptable board width	Moderately stable (MS)	Moderately stable (MS)
140 - 145 mm		Roots <i>complies with DTU 51.4³</i>

HardWood Clip® and SoftWood Clip™ fasteners should not be used with non-heat-treated softwood boards.

MODIFIED WOOD AND BAMBOO (NOT HANDLED BY NF DTU 51.4)				
Board profile				
Acceptable board width	Stable (S)		Stable (S)	
< 140 mm	HardWood Clip <i>ACCOYA® : complies with DTU 51.4⁵</i>	SoftWood Clip	HardWood Clip + local grooving ¹ <i>ACCOYA® : complies with DTU 51.4⁵</i>	SoftWood Clip + local grooving ¹
140 - 145 mm	HardWood Clip <i>ACCOYA® : complies with DTU 51.4⁵</i>	SoftWood Clip	Roots	HardWood Clip + local grooving ¹ <i>ACCOYA® : complies with DTU 51.4⁵</i> SoftWood Clip + local grooving ¹
> 145 mm	HardWood Clip <i>ACCOYA® : complies with DTU 51.4⁵</i>	SoftWood Clip	HardWood Clip + local grooving ¹ <i>ACCOYA® : complies with DTU 51.4⁵</i>	SoftWood Clip + local grooving ¹

Nowadays, manufacturers offer a number of non-traditional wood or bamboo decking and cladding boards on the market that are not defined in the NF DTU 51.4 standard. In the table above, NOVLEK® offers hidden fastening solutions adapted to some of them: thermally modified wood planks (ash, pine, etc.), **chemically modified wood boards (Accoya®, Kebony®, etc.)**, densified bamboo boards (Moso®, etc.).

1. Requires local grooving with a biscuit joiner (Lamello® type) | 2. FCBA tests: FCBA-2010.461.1263 | 3. FCBA tests: FCBA-2019.175.2230 and FCBA-2010.175.3290 | 4. FCBA tests: FCBA-2018.387.1177 | 5. FCBA tests: FCBA-DT 2016.511.2348

DETAILED INFORMATION



HardWood Clip®
pages 15-31



HardWood Clip®
local grooving
page 21



SoftWood Clip™
pages 33-41



Roots
pages 43-53

HIDDEN FASTENERS

INSTALLATION USING STANDARD BOARDS AND LOCAL GROOVING

BENEFITS



SUITABLE FOR STANDARD BOARDS



FASTER THAN TRADITIONAL SCREW INSTALLATION



EDGE STRENGTH SIMILAR TO A STANDARD SOLID EDGE BOARD



EDGE STABILITY SIMILAR TO A STANDARD SOLID EDGE BOARD



VERY EASY AND QUICK TO GROOVE WITH A BISCUIT JOINER



SOLUTION TO AN INFINITE NUMBER OF SITUATIONS TOTAL FREEDOM

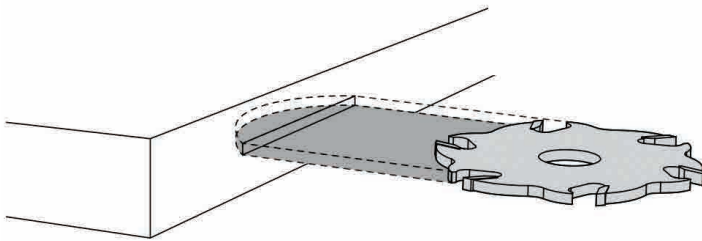

HardWood Clip® hidden fasteners can be fitted quickly and easily to standard solid-edge boards

The boards are simply grooved locally at each intersection between boards and joists. Grooving is quick and can be done without any fuss using a Lamello® biscuit joiner. Many power tool manufacturers offer them in their range.

Although perceived as slower than installing boards purchased pre-grooved along their length, this solution has long been **preferred by many users of HardWood Clip® fasteners**, who have adapted their work organization on the job site to accommodate this technique, which is **much quicker and easier than the traditional installation technique using surface screws**.

The local grooving method **preserves the strength and stability of boards with solid edges**, making it the solution of choice for installing HardWood Clip® fasteners especially when laying modified wood boards, which are much more fragile because they have been heat-treated (**Accoya®, Kebony®, heat-treated wood**). The risk of damage to the profiles during transport or multiple handling of the boards is almost non-existent, whereby losses are minimised.

Fitting HardWood Clip® fasteners on standard locally grooved boards offers numerous benefits and guarantees that the system will be fully concealed to produce a result that will delight the most discerning customers.





Click on the photo to watch the video

FASTER THAN TRADITIONAL SCREW INSTALLATION

The local grooving of the boards can be done directly on the plank when it has been laid, when it is cut to length (after marking the groove locations), or in the workshop in advance, based on the pre-marked layout. This solution offers a high degree of flexibility both in terms of work organisation and timber supply.

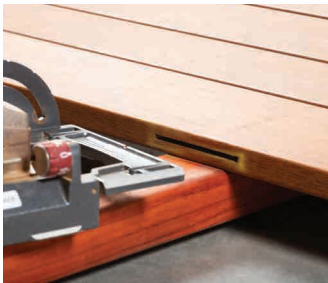

Strength and stability of the edges of the boards

Thanks to its very short, rounded groove, the board retains the same strength and edge stability as a standard board with solid edges. For a 3m-long board, local grooving means a solid edge remains over 84% of its length. FCBA recommends local grooving for very unstable species such as Bangkirai which has a big difference between tangential and radial coefficients of shrinkage.



4mm-thick groove

The cutters on most standard biscuit joiners have a width of 4mm, making it possible to rout the groove required to fit HardWood Clip® or SoftWood Clip™ hidden fasteners.



Precise and constant positioning of the groove

Using a Lamello® biscuit joiner ensures that each groove is positioned extremely precisely and consistently.



Particularly suitable for the most fragile of timber

Local grooving is particularly recommended for thin boards (20-21 mm) from modified woods such as Accoya®, Kebony® or heat-treated woods, which are physically more fragile, especially at the edges of the boards. Local grooving guarantees that the edges of the boards are as strong as a standard board with solid edges.

USE

This solution is suitable for both **HardWood Clip®** and **SoftWood Clip™** fasteners and can be applied on decking and cladding.



HardWood Clip®



SoftWood Clip™



HIDDEN FASTENERS
WITH STAINLESS STEEL REINFORCEMENT

HardWood Clip®



HIDDEN FASTENERS

WITH STAINLESS STEEL REINFORCEMENT

BENEFITS



SCREWING BOARDS
ONTO JOISTS



REVERSIBLE BOARDS
BOTH SIDES CAN BE USED



QUICK AND EASY INSTALLATION
40% TIME SAVINGS



EXTREME STABILITY
IN ALL WEATHERS



REGULAR, EVEN SPACING
BETWEEN BOARDS ALL YEAR
ROUND



ABSORBS SWELLING
OF THE BOARDS



EXCEPTIONAL MECHANICAL
STRENGTH



EXTREMELY DURABLE



UNCOMPROMISING QUALITY
AND PERFORMANCE

High hardness AISI 304 stainless steel reinforcement

Provides unparalleled rigidity and strength to the fastener, ensuring the board is properly clamped to the joist, and the decking is highly stable, even with the hardest woods.



Plastic resin shell

High performance polymer to cope with the mechanical and physical stresses on the fastener.

Gripping ribs

Hold the fastener in place while it is being screwed in.

Integrated spacer

Ensures appropriate, constant and even spacing between boards. It is designed to absorb the swelling of the boards without damaging the wood.

3 thicknesses available: 3, 5 and 7 mm.

Protective cover for the stainless steel reinforcement

Protects the stainless steel reinforcement, preventing damage to it from the screw head during screwing. Guarantees durability of the fastener.



Black antireflective finish

Ensures full UV protection, as well as complete discretion. Does not reflect the sun's rays or light.

Patented fastener



Stainless steel screw A2 AISI 304

Highly resistant to a saline atmosphere. Solid "Antique" colour stainless steel.



Small head

Ground serrations, Torx SPAX T-STAR plus.

SPAX ground serrations profile

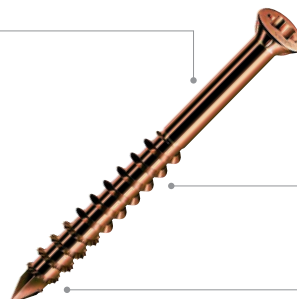

CUT point

For fast, safe screwing.



Click on the photo to watch the video

USE

HardWood Clip® is the most advanced, effective fastening system on the market for timber decking and cladding, thanks to its exclusive and outstanding technical characteristics.

The invisible HardWood Clip® fasteners ensure complete stability over time, along with their high-end aesthetic and unparalleled durability.

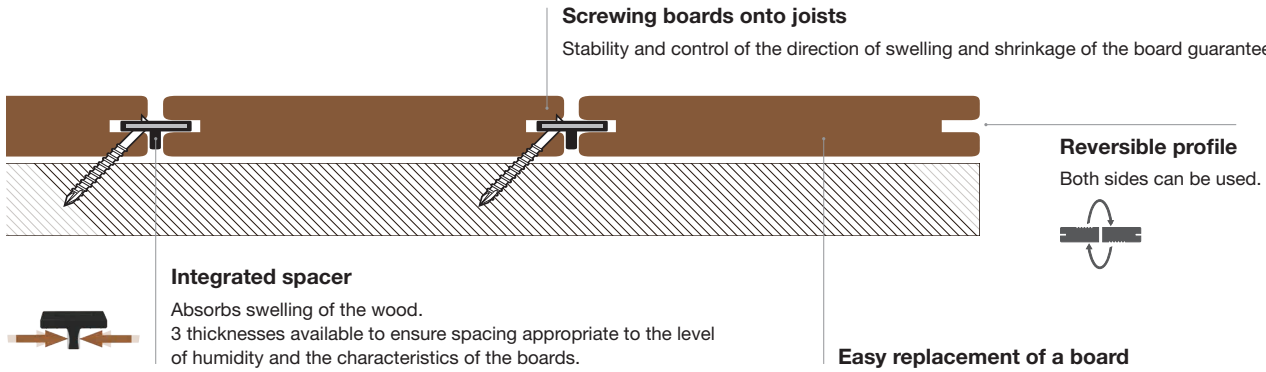

USE *	TROPICAL WOOD **	BROAD-LEAVED SPECIES	RESINOUS WOOD	MODIFIED WOOD			
		OAK CHESTNUT **		ACCOYA® **	KEBONY®	HEAT-TREATED	BAMBOO
Residential	✓	✓	✗	✓	✓	✓	✓
Public / Commercial	✓	✓	✗	✓	✓	✗	✓
Coastal	✓	✓	✗	✓	✓	✓	✓
Decking	✓	✓	✗	✓	✓	✓	✓
Pool beaches	✓	✓	✗	✓	✓	✓	✓
Cladding	✓	✓	✗	✓	✓	✓	✓

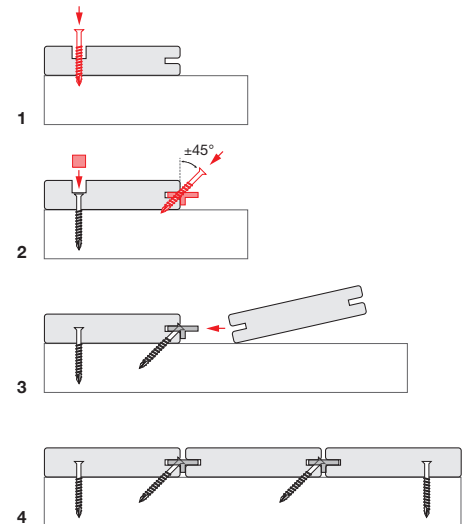

* Scrupulously respect the requirements linked to the chosen species (NF B 54-040), the requirements of the standards and regulations in force (notably NF-DTU 51.4 and 41.2), maximum width/thickness ratio values, installation and grooving instructions, manufacturer's instructions, regulations in force and good practices. Some varieties must be used with special care or are to be avoided, due, notably to their unstable nature, to their range of movement, to their fragility or certain specific properties that could give rise to weaknesses with respect to the boards. For further information, please contact your retailer, your timber supplier or send an e-mail to info@novlek.com.

** Respect the conclusions and recommendations of product description and evaluation folders produced by the FCBA (see COMPLIANCE below).



COMPLIANCE

DTU 51.4 Fastening requirements for decking boards

HardWood Clip® is the only invisible fastening system to have had three technical evaluations confirming its compliance with the requirements of standard NF DTU 51.4 covering fasteners for decking boards.

- Tropical species :** FCBA-2010.461.1263
- Oak and chestnut :** FCBA-2018.387.1177
- Accoya® :** FCBA-DT 2016.511.2348



The FCBA has assessed the HardWood Clip® fasteners as compliant with the requirements of DTU 51.4 for wooden planking. HardWood Clip® meets all the various criteria and acceptability thresholds specified in the DTU 51.4 for resistance to tearing and shearing, as well as for stability of the planking (tolerances on the finished planking and during its working life).

HIDDEN FASTENERS

WITH STAINLESS STEEL REINFORCEMENT

3 SIZES TO GUARANTEE APPROPRIATE SPACING BETWEEN BOARDS



Models	S	M	L
Spacing between boards during installation	3 mm 	5 mm 	7 mm
Use* (moisture content of the boards during installation)			
Max. allowed swelling	0 mm	4 mm	6 mm
Max. allowed shrinking	10 mm	9 mm	8 mm
Materials	Polypropylene and fibreglass Stainless steel AISI 304	Polyethylene Stainless steel AISI 304	Polyethylene Stainless steel AISI 304
Colour	Black, anti-reflection	Black, anti-reflection	Black, anti-reflection
UV resistance	Yes	Yes	Yes
Resistance to high and low temperatures	Excellent	Excellent	Excellent

* To be adjusted on a case-by-case basis, depending, notably on the species, width boards, environment, exposure and climate conditions. Respect the requirements of DTU 51.4.

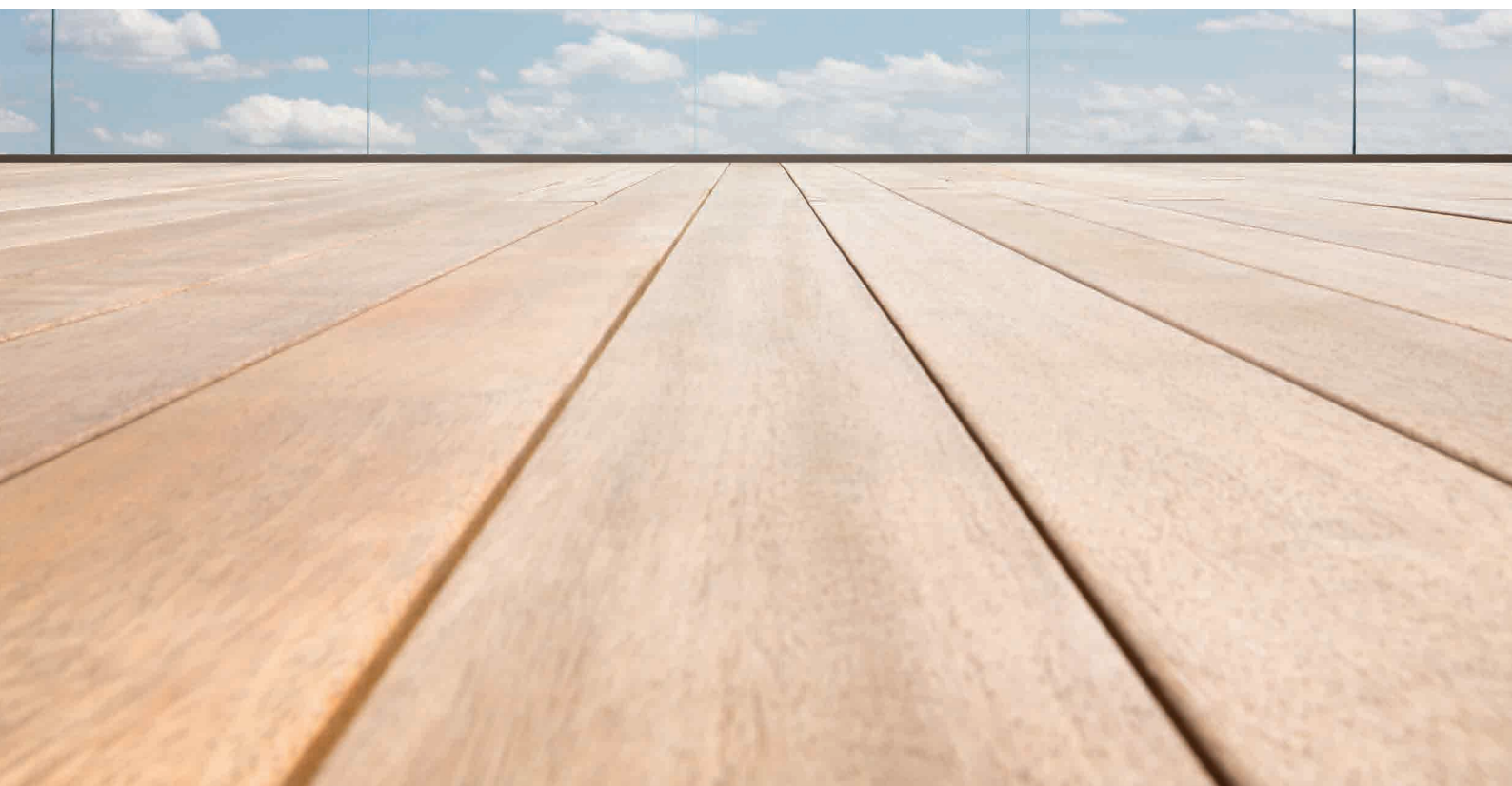



PROFILES

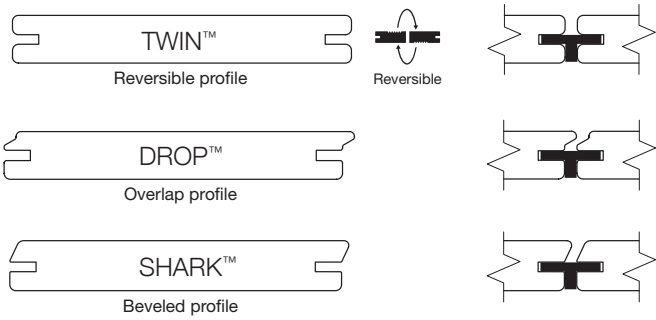

	TWIN™	DROP™	SHARK™
Decking	•	•	•
Vertical cladding	•	•	•
Horizontal cladding	Sheltered or interior	•	•

Available in various finishes, thicknesses from 20 mm and widths up to 145 mm. Other larger sizes, depending on species, thickness, installation conditions, etc.

GROOVING



Grooving along the whole length, with a 4-sided planer or spindle moulder.



Local grooving, with a Lamello® type biscuit joiner or a router.

HIDDEN FASTENERS

WITH STAINLESS STEEL REINFORCEMENT

SPECIES ACCEPTABLE FOR THE HARDWOOD CLIP® FASTENING SYSTEM

TROPICAL SPECIES			
Acceptable board width	Stable (S)	Moderately stable (MS)	Unstable (PS)
< 140 mm	HardWood Clip <i>complies with DTU 51.4¹</i>	HardWood Clip <i>complies with DTU 51.4¹</i>	✘
140 - 145 mm	HardWood Clip <i>complies with DTU 51.4¹</i>	HardWood Clip <i>complies with DTU 51.4¹</i>	✘

The use of HardWood Clip® fasteners with certain tropical species such as Bilinga, Bangkirai, Yellow Cumaru, Tali, etc. that the NF B 54-040 standard classifies as moderately stable (MS) must be studied on a case-by-case basis, as special attention is required, in particular because of the problems that their properties could create. FCBA recommends local grooving for moderately stable species such as Bangkirai which has a big difference between tangential and radial coefficients of shrinkage.

The use of HardWood Clip® hidden fasteners is not recommended with tropical wood species that the NF B 54-040 standard classifies as unstable (PS) due to their particular physical properties and lack of stability, especially when drying out.

TEMPERATE HARDWOODS			
Acceptable board width	Stable (S)	Moderately stable (MS)	Unstable (PS)
≤ 110 mm	-	HardWood Clip <i>complies with DTU 51.4²</i>	✘

The use of HardWood Clip® hidden fasteners is not recommended with temperate wood species that the NF B 54-040 standard (Robinia) classifies as unstable (PS) due to their particular physical properties and lack of stability, especially when drying out.

SOFTWOOD SPECIES (EXCLUDING THERMO-MODIFIED)			
Acceptable board width	Stable (S)	Moderately stable (MS)	Unstable (PS)
-	-	✘	-

HardWood Clip® fasteners should not be used with non-heat-treated softwood boards.

MODIFIED WOOD AND BAMBOO (NOT HANDLED BY NF DTU 51.4, EXCEPT FOR ACCOYA®)			
Acceptable board width	Stable (S)	Moderately stable (MS)	Unstable (PS)
< 140 mm	HardWood Clip <i>ACCOYA® : complies with DTU 51.4³</i>	-	-
140 - 145 mm	HardWood Clip <i>ACCOYA® : complies with DTU 51.4³</i>	-	-
> 145 mm	HardWood Clip <i>ACCOYA® : complies with DTU 51.4³</i>	-	-

Whatever the wood species of the boards, the requirements of NF DTU 51.4 and NF B 54-040 must be scrupulously respected, as must FCBA recommendation (see test reports below) and the installation instructions supplied with HardWood Clip® fasteners.

1. FCBA tests: FCBA-2010.461.1263 | 2. FCBA tests: FCBA-2018.387.1177 | 3. FCBA tests: FCBA-DT 2016.511.2348



Click on the photo to watch the video

INSTALLATION USING STANDARD BOARDS AND LOCAL GROOVING

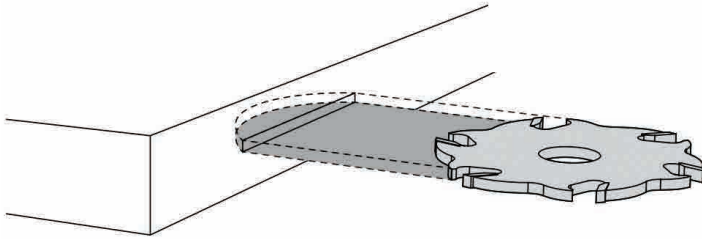

HardWood Clip® hidden fasteners can be fitted quickly and easily to standard solid-edge boards

ADVANTAGES



SUITABLE FOR STANDARD BOARDS



FASTER THAN TRADITIONAL SCREW INSTALLATION



EDGE STRENGTH SIMILAR TO A STANDARD SOLID EDGE BOARD



EDGE STABILITY SIMILAR TO A STANDARD SOLID EDGE BOARD



VERY EASY AND QUICK TO GROOVE WITH A BISCUIT JOINER



SOLUTION TO AN INFINITE NUMBER OF SITUATIONS TOTAL FREEDOM



More info
pages 12-13

HIDDEN FASTENERS

WITH STAINLESS STEEL REINFORCEMENT

USE FOR CLADDING



HardWood Clip® invisible fasteners guarantee quick and easy installation of cladding boards thanks to its integrated spacer, which automatically ensures they are correctly spaced and perfectly parallel to each other.

Having the boards screwed to their supports with HardWood Clip® fasteners makes installation much easier, and also guarantees their strength, stability and beauty over the lifetime of the facade covering.

HardWood Clip® ensures they are firmly fixed, whether laid horizontally or vertically.

The various technical profiles available for HardWood Clip® provide a solution for every cladding project, whether with closed or opened joints, domestic or public.

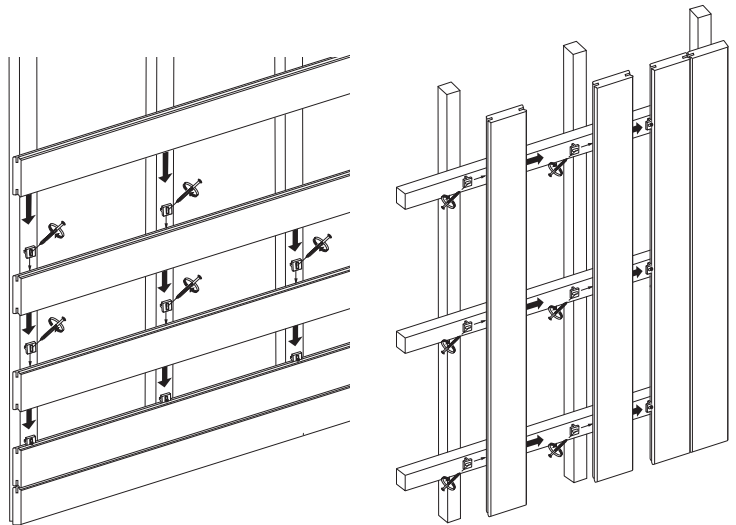



HIDDEN FASTENERS WITH STAINLESS STEEL REINFORCEMENT



- ± 7m²
90mm
- ± 10m²
120mm
- ± 11m²
140mm

CONTENTS

Hardwood Clip® CLASSIC | ± 11 m²

Estimate based on board width of 140 mm and joists centre to centre distance of 45 cm

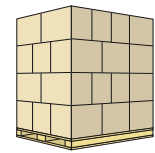

Model	Article code	EAN code	Kit		Box 8 Kits/Box		Pallet 288 Kits/Pallet	
			Dimensions (mm)	Weight	Dimensions (mm)	Weight	Dimensions (mm)	Weight
S - 3 mm	HW-S-185-12	5425 03355 000 4	245 x 190 x 95	2,05 kg	395 x 260 x 400	16,80 kg	1200 x 800 x 1750	630 kg
M - 5 mm	HW-M-185-12	5425 03355 001 1	245 x 190 x 95	2,00 kg	395 x 260 x 400	16,40 kg	1200 x 800 x 1750	615 kg
L - 7 mm	HW-L-185-12	5425 03355 002 8	245 x 190 x 95	2,04 kg	395 x 260 x 400	16,70 kg	1200 x 800 x 1750	626 kg

Plug variants

HardWood Clip® CLASSIC is available, at no extra cost, with wooden plugs in the following species (article codes below):

Model	Padouk	Kebony®	Larch	Cumaru	Merbau
S - 3 mm	HW-S-185-12_2	HW-S-185-12_4	HW-S-185-12_5	HW-S-185-12_6	HW-S-185-12_7
M - 5 mm	HW-M-185-12_2	HW-M-185-12_4	HW-M-185-12_5	HW-M-185-12_6	HW-M-185-12_7
L - 7 mm	HW-L-185-12_2	HW-L-185-12_4	HW-L-185-12_5	HW-L-185-12_6	HW-L-185-12_7



HIDDEN FASTENERS WITH STAINLESS STEEL REINFORCEMENT



- ± 17m²
90mm
- ± 24m²
120mm
- ± 27m²
140mm

CONTENTS

Hardwood Clip®

PRO | ± 27 m²

Estimate based on board width of 140 mm and joists centre to centre distance of 45 cm

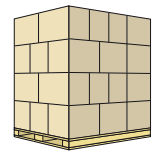
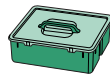

Model	Article code	EAN code	Kit		Box 3 Kits/Box		Pallet 108 Kits/Pallet	
			Dimensions (mm)	Weight	Dimensions (mm)	Weight	Dimensions (mm)	Weight
S - 3 mm	HW-S-450-12	5425 03355 010 3	360 x 270 x 140	4,95 kg	376 x 281 x 400	15,35 kg	1200 x 1000 x 1750	578 kg
M - 5 mm	HW-M-450-12	5425 03355 011 0	360 x 270 x 140	4,86 kg	376 x 281 x 400	15,08 kg	1200 x 1000 x 1750	568 kg
L - 7 mm	HW-L-450-12	5425 03355 012 7	360 x 270 x 140	4,91 kg	376 x 281 x 400	15,25 kg	1200 x 1000 x 1750	574 kg

Plug variants

HardWood Clip® PRO is available, at no extra cost, with wooden plugs in the following species (article codes below):

Model	Padouk	Kebony®	Larch	Cumaru	Merbau
S - 3 mm	HW-S-450-12_2	HW-S-450-12_4	HW-S-450-12_5	HW-S-450-12_6	HW-S-450-12_7
M - 5 mm	HW-M-450-12_2	HW-M-450-12_4	HW-M-450-12_5	HW-M-450-12_6	HW-M-450-12_7
L - 7 mm	HW-L-450-12_2	HW-L-450-12_4	HW-L-450-12_5	HW-L-450-12_6	HW-L-450-12_7



HIDDEN FASTENERS

WITH STAINLESS STEEL REINFORCEMENT



± 19 m²

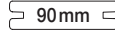

± 26 m²

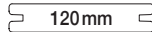

± 30 m²

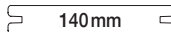

CONTENTS



Hardwood Clip®

PRO Refill | ± 30 m²

Estimate based on board width of 140 mm and joists centre to centre distance of 45 cm

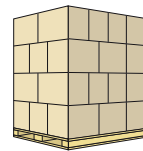

Model	Article code	EAN code	Kit		Pallet 99 Kits/Palet	
			Dimensions (mm)	Weight	Dimensions (mm)	Weight
S - 3 mm	HW-S-RF500-12	5425 03355 018 9	360 x 270 x 140	4,95 kg	1200 x 1000 x 1750	578 kg
M - 5 mm	HW-M-RF500-12	5425 03355 019 6	360 x 270 x 140	4,86 kg	1200 x 1000 x 1750	568 kg



reddot design award
winner 2010



FCBA N° 2010-461.1208



REFILL PRO: AN ECO-FRIENDLY AND ECONOMICAL SOLUTION



The **REFILL** for the HardWood Clip® PRO kit allows the craft worker to reuse the HardWood Clip® PRO plastic box almost indefinitely when it is empty whenever necessary.

NÖVLEK® has developed the **REFILL** to provide craft workers with a solution that reduces packaging materials on-site and facilitates their disposal, as well as combatting unnecessary waste by optimising and streamlining its contents.

Choosing **REFILL** PRO allows you to optimise your purchases and makes life easier on the site, in addition to protecting our planet.

BENEFITS



WASTE
REDUCTION



ECO-FRIENDLY SOLUTION
100% RECYCLED CARDBOARD
100% RECYCLABLE



ECONOMICAL
STREAMLINING OF CONTENTS
ANTI-WASTE

Eco-friendly packaging

99% less plastic.
No overpackaging.

100% recycled and 100% recyclable FSC cardboard

Cardboard waste is not bulky and is easy
to dispose of and recycle.



Reuse of the PRO box and spacers

Once empty, the PRO case can be refilled with the REFILL and reused almost indefinitely, as can the spacers supplied with it.

The REFILL means no more piles of plastic boxes and hundreds of spacers and plugs that you don't know what to do with.



Streamlined and anti-waste contents

The REFILL PRO only contains fasteners, screws, Torx bits and pre-drilling bits. Other components (spacers, plugs) are not included in the REFILL because they are already part of the basic PRO case which can be filled when empty.

The quantity of fasteners matches the number of screws because the additional screws needed for the start and end boards or other finishes are also included in the basic kit.

HIDDEN FASTENERS

WITH STAINLESS STEEL REINFORCEMENT



- ± 3m²
90mm
- ± 4m²
120mm
- ± 5m²
140mm

CONTENTS



Hardwood Clip®

MINI | ± 5 m²

Estimate based on board width of 140 mm and joists centre to centre distance of 45 cm

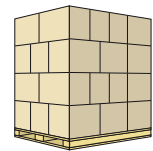

Model	Article code	EAN code	Kit		Box 3 Kits/Box		Pallet 168 Kits/Pallet	
			Dimensions (mm)	Weight	Dimensions (mm)	Weight	Dimensions (mm)	Weight
S - 3 mm	HW-S-85-12	5425 03355 020 2	155 x 120 x 125	0,97 kg	365 x 160 x 135	3,05 kg	1200 x 800 x 690	196 kg
M - 5 mm	HW-M-85-12	5425 03355 021 9	155 x 120 x 125	0,95 kg	365 x 160 x 135	2,98 kg	1200 x 800 x 690	192 kg
L - 7 mm	HW-L-85-12	5425 03355 022 6	155 x 120 x 125	0,95 kg	365 x 160 x 135	2,98 kg	1200 x 800 x 690	192 kg



reddot design award
winner 2010



FCBA N° 2010.461.1208





HIDDEN FASTENERS WITH STAINLESS STEEL REINFORCEMENT



HardWood Clip®



±7m²
90mm

±11m²
145mm

±15m²
190mm



Hardwood Clip® **CLASSIC | ±11 m²**

Estimate based on board width of 140 mm
and joists centre to centre distance of 45 cm

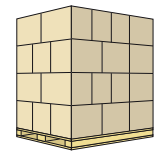

Model	Article code	EAN code	Kit		Box 8 Kits/Box		Pallet 288 Kits/Pallet	
			Dimensions (mm)	Weight	Dimensions (mm)	Weight	Dimensions (mm)	Weight
S - 3 mm	HW-S-185-03	5425 03355 003 5	245 x 190 x 95	2,01 kg	395 x 260 x 400	16,46 kg	1200 x 800 x 1750	618 kg
M - 5 mm	HW-M-185-03	5425 03355 004 2	245 x 190 x 95	1,95 kg	395 x 260 x 400	16,01 kg	1200 x 800 x 1750	601 kg
L - 7 mm	HW-L-185-03	5425 03355 007 3	245 x 190 x 95	2,00 kg	395 x 260 x 400	16,41 kg	1200 x 800 x 1750	616 kg



The information shown in this document is given for information purposes and is not contractual. It may be changed at any time without prior notice. All rights reserved ARCHIWOOD sprl.

HIDDEN FASTENERS WITH STAINLESS STEEL REINFORCEMENT



HardWood Clip®

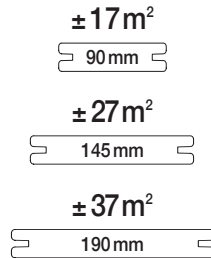

CONTENTS

Hardwood Clip®

PRO | ± 27 m²

Estimate based on board width of 140 mm and joists centre to centre distance of 45 cm

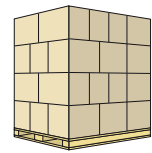
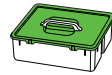

Model	Article code	EAN code	Kit		Box 3 Kits/Box		Pallet 108 Kits/Pallet	
			Dimensions (mm)	Weight	Dimensions (mm)	Weight	Dimensions (mm)	Weight
S - 3 mm	HW-S-450-03	5425 03355 013 4	360 x 270 x 140	4,87 kg	376 x 281 x 400	15,11 kg	1200 x 1000 x 1750	569 kg
M - 5 mm	HW-M-450-03	5425 03355 014 1	360 x 270 x 140	4,78 kg	376 x 281 x 400	14,84 kg	1200 x 1000 x 1750	559 kg
L - 7 mm	HW-L-450-03	5425 03355 017 2	360 x 270 x 140	4,83 kg	376 x 281 x 400	14,99 kg	1200 x 1000 x 1750	565 kg



The information shown in this document is given for information purposes and is not contractual. It may be changed at any time without prior notice. All rights reserved ARCHIWOOD sprl.



HIDDEN FASTENERS
FOR STABLE MODIFIED WOOD

SoftWood Clip™



HIDDEN FASTENERS

FOR STABLE MODIFIED WOOD

BENEFITS



SCREWING BOARDS
ONTO JOISTS



REVERSIBLE BOARDS
BOTH SIDES CAN BE USED



QUICK AND EASY INSTALLATION
40% TIME SAVINGS



EXTREME STABILITY
IN ALL WEATHERS



REGULAR, EVEN SPACING
BETWEEN BOARDS ALL YEAR
ROUND



ABSORBS SWELLING
OF THE BOARDS



HIGH MECHANICAL
STRENGTH



EXTREMELY DURABLE



UNCOMPROMISING QUALITY
AND PERFORMANCE



45° screw guide

To help in installing and ensuring a perfect screw angle.



Plastic resin shell

High performance polymer to cope with the mechanical and physical stresses on the fastener.

Gripping ribs

Hold the fastener in place while it is being screwed in.

Integrated spacer

Ensures appropriate, constant and even spacing between boards. It is designed to absorb the swelling of the boards without damaging the wood. 2 thicknesses available: 5 and 7 mm.

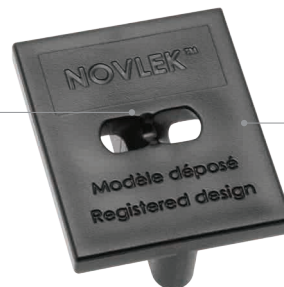

Black antireflective finish

Ensures full UV protection, as well as complete discretion. Does not reflect the sun's rays or light.



Stainless steel screw A2 AISI 304

Highly resistant to a saline atmosphere. Solid "Antique" colour stainless steel.



Small head

Ground serrations, Torx SPAX T-STAR plus.

SPAX ground serrations profile

CUT point

For fast, safe screwing.



Click on the photo to watch the video

USE

The invisible SoftWood Clip™ fasteners are designed especially for decking and cladding, in stable modified timber: heat-treated pine, heat-treated ash, Accoya®, Kebony®, bamboo, etc. SoftWood Clip™ fasteners ensure complete stability over time, along with their high-end aesthetic and unparalleled durability.

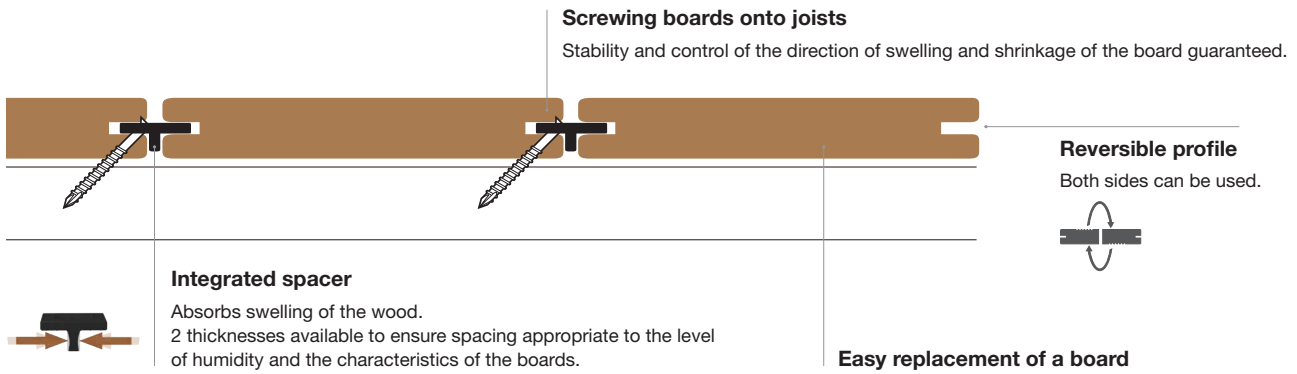

USE*	TROPICAL WOOD	BROAD-LEAVED SPECIES OAK CHESTNUT	RESINOUS WOOD	MODIFIED WOOD			
				ACCOYA®	KEBONY®	HEAT-TREATED	BAMBOO
Residential	✗	✗	✗	✓	✓	✓	✓
Public / Commercial	✗	✗	✗	✓	✓	✗	✓
Coastal	✗	✗	✗	✓	✓	✓	✓
Decking	✗	✗	✗	✓	✓	✓	✓
Pool beaches	✗	✗	✗	✓	✓	✓	✓
Cladding	✗	✗	✗	✓	✓	✓	✓

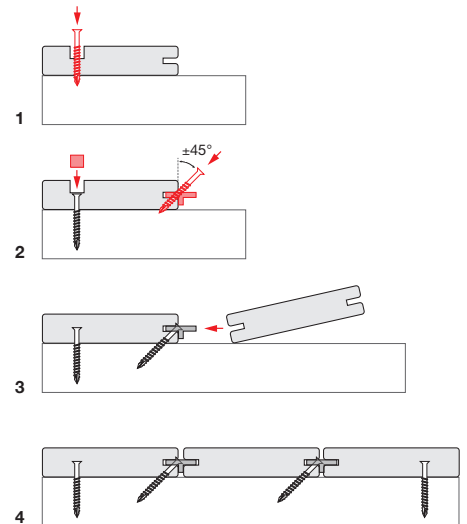

* Scrupulously respect the requirements linked to the chosen species (NF B 54-040), the requirements of the standards and regulations in force (notably NF-DTU 51.4 and 41.2), maximum width/thickness ratio values, installation and grooving instructions, manufacturer's instructions, regulations in force and good practices. Some varieties must be used with special care or are to be avoided, due, notably to their unstable nature, to their range of movement, to their fragility or certain specific properties that could give rise to weaknesses with respect to the boards. For further information, please contact your retailer, your timber supplier or send an e-mail to info@novlek.com.

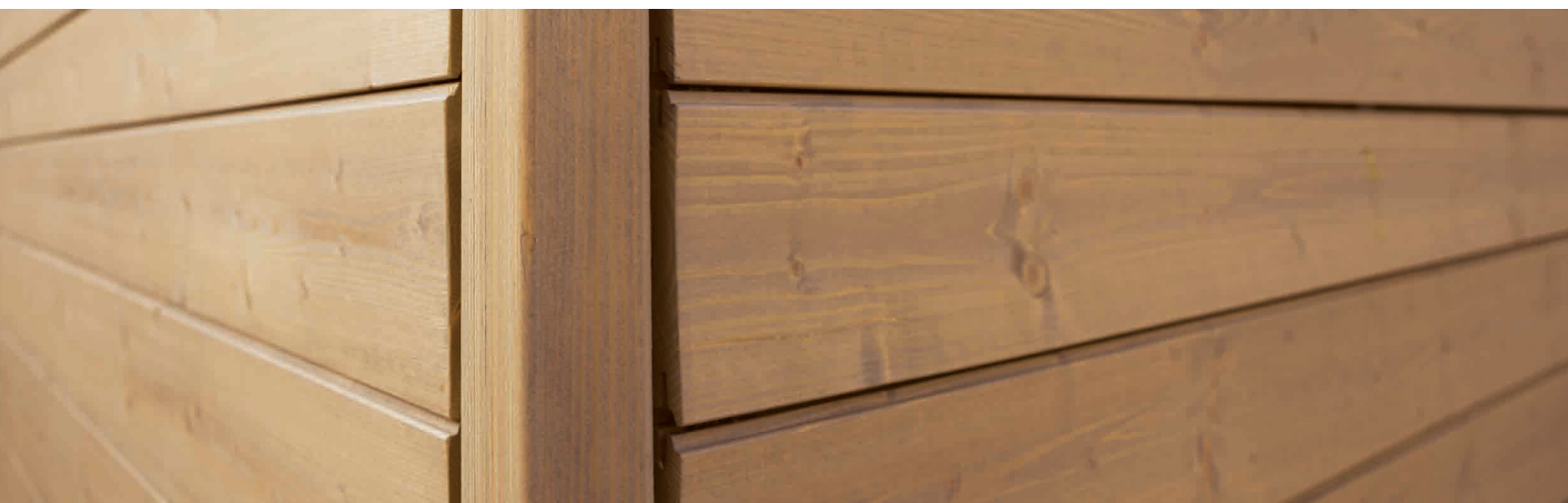

HIDDEN FASTENERS

FOR STABLE MODIFIED WOOD

2 SIZES TO GUARANTEE APPROPRIATE SPACING BETWEEN BOARDS



Models	M	L
Spacing between boards during installation	<p>5 mm</p>	<p>7 mm</p>
Max. allowed swelling	4 mm	6 mm
Max. allowed shrinking	9 mm	8 mm
Material	High Impact Polyamide	High Impact Polyamide
Colour	Black, anti-reflection	Black, anti-reflection
UV resistance	Yes	Yes
Resistance to high and low temperatures	Excellent	Excellent



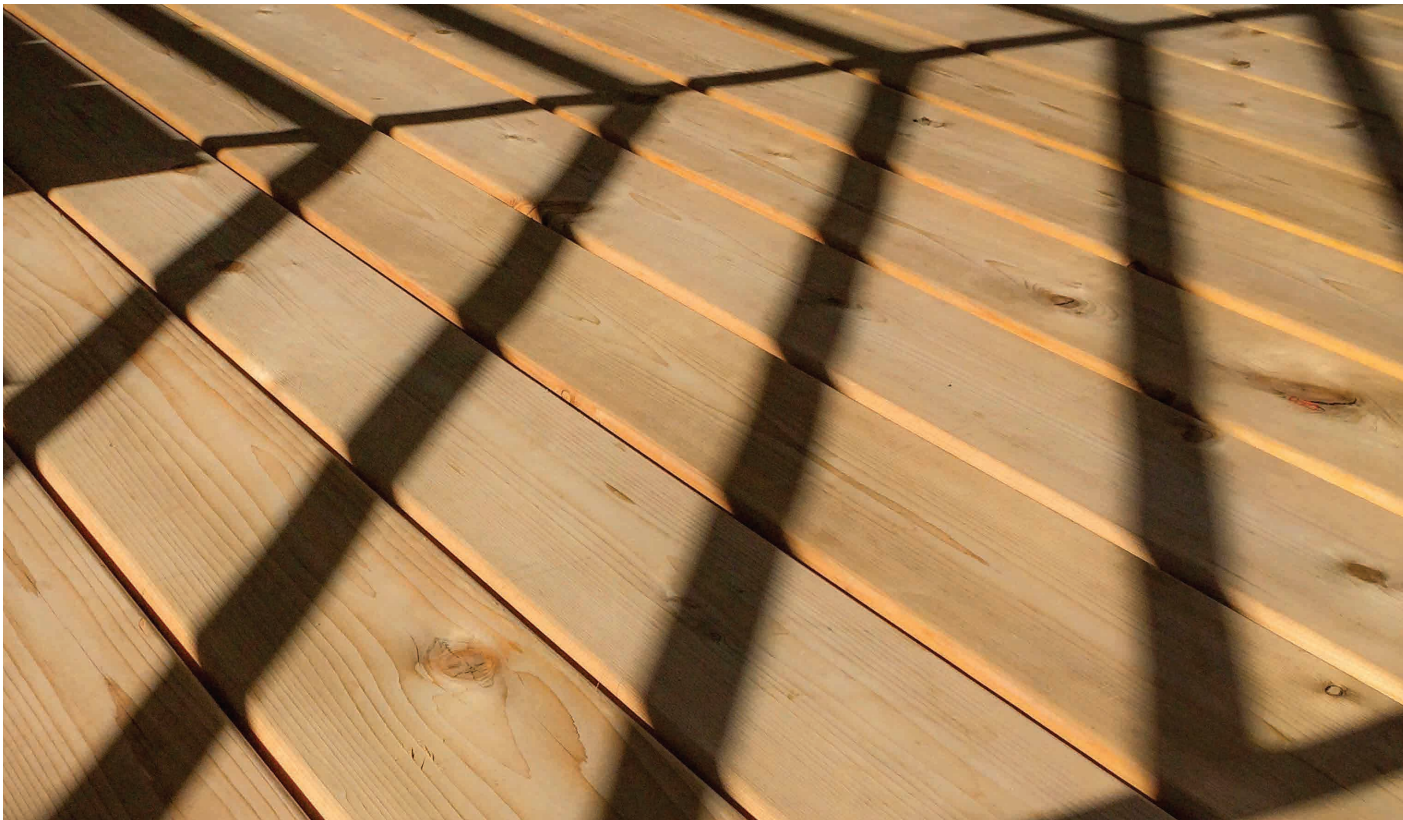

PROFILES

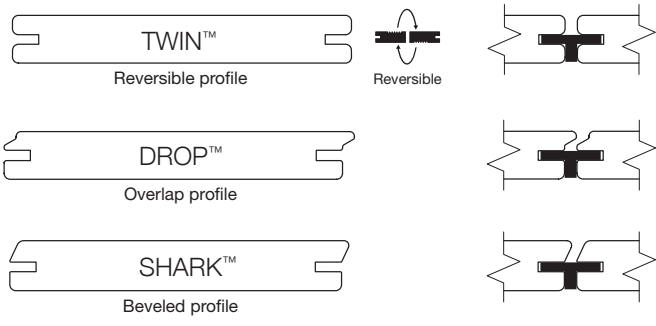

	TWIN™	DROP™	SHARK™
Decking	•	•	•
Vertical cladding	•	•	•
Horizontal cladding	Sheltered or interior	•	•

Available in various finishes, thicknesses from 20 mm and widths up to 145 mm. Other larger sizes, depending on species, thickness, installation conditions, etc.

GROOVING



Grooving along the whole length, with a 4-sided planer or spindle moulder.



Local grooving, with a Lamello® type biscuit joiner or a router.

HIDDEN FASTENERS

FOR STABLE MODIFIED WOOD

USE FOR CLADDING



SoftWood Clip™ invisible fasteners guarantee quick and easy installation of cladding boards thanks to its integrated spacer, which automatically ensures they are correctly spaced and perfectly parallel to each other.

Having the boards screwed to their supports with SoftWood Clip™ fasteners makes installation much easier, and also guarantees their strength, stability and beauty over the lifetime of the facade covering.

SoftWood Clip™ ensures they are firmly fixed, whether laid horizontally or vertically.

The various technical profiles available for SoftWood Clip™ provide a solution for every cladding project, whether with closed or opened joints, domestic or public.

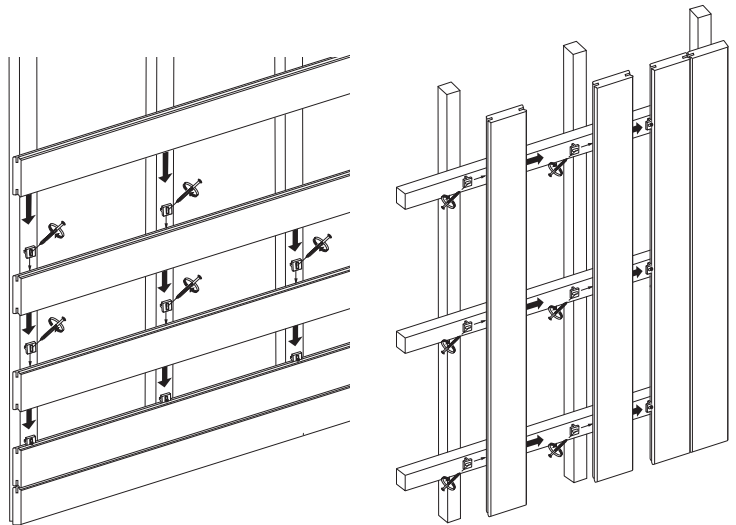



HIDDEN FASTENERS FOR STABLE MODIFIED WOOD



- ± 8m²
90mm
- ± 11m²
120mm
- ± 12m²
140mm

CONTENTS



Softwood Clip™ CLASSIC | ± 12m²

Estimate based on board width of 140 mm and joists centre to centre distance of 45 cm

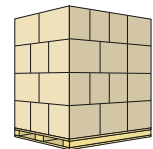

Model	Article code	EAN code	Kit		Box 8 Kits/Box		Pallet 288 Kits/Pallet	
			Dimensions (mm)	Weight	Dimensions (mm)	Weight	Dimensions (mm)	Weight
M - 5 mm	SW-M-200-12	5425 03355 030 1	245 x 190 x 95	1,55 kg	395 x 260 x 400	12,90 kg	1200 x 800 x 1750	489 kg
L - 7 mm	SW-L-200-12	5425 03355 031 8	245 x 190 x 95	1,57 kg	395 x 260 x 400	13,03 kg	1200 x 800 x 1750	494 kg



The information shown in this document is given for information purposes and is not contractual. It may be changed at any time without prior notice. All rights reserved ARCHIWOOD sprl.

HIDDEN FASTENERS FOR STABLE MODIFIED WOOD

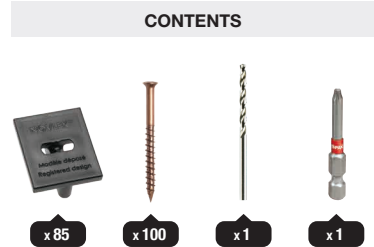
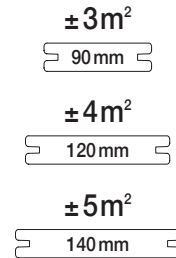

Softwood Clip™

MINI | ± 5 m²

Estimate based on board width of 140 mm and joists centre to centre distance of 45 cm

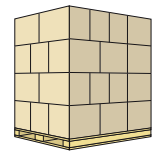

Model	Article code	EAN code	Kit		Box 3 Kits/Box		Pallet 168 Kits/Pallet	
			Dimensions (mm)	Weight	Dimensions (mm)	Weight	Dimensions (mm)	Weight
M - 5 mm	SW-M-85-12	5425 03355 052 3	155 x 120 x 125	0,74 kg	365 x 160 x 135	2,34 kg	1200 x 800 x 690	156 kg
L - 7 mm	SW-L-85-12	5425 03355 053 0	155 x 120 x 125	0,75 kg	365 x 160 x 135	2,38 kg	1200 x 800 x 690	158 kg



The information shown in this document is given for information purposes and is not contractual. It may be changed at any time without prior notice. All rights reserved ARCHWOOD sprl.



HIDDEN FASTENERS
FOR STANDARD BOARDS

Roots



HIDDEN FASTENERS

FOR STANDARD BOARDS



BENEFITS



FOR STANDARD BOARDS
STABLE AND MODERATELY
STABLE TROPICAL WOOD



FULL VENTILATION OF
UNDERSIDE OF BOARDS
NO WATER RETENTION



VERY EASY TO INSTALL



EXTREME STABILITY
IN ALL WEATHERS



PROTECTION OF THE JOIST
WITH CAPPING



REUSABLE AFTER
DISMANTLING



EXCEPTIONAL MECHANICAL
STRENGTH



FASTENERS AND JOISTS
COMPLETELY INVISIBLE



UNCOMPROMISING QUALITY
AND PERFORMANCE

Exclusive design

The original design of the fastening gives it very high mechanical strength and rigidity, while providing the maximum supporting surface for the board.

Assembly tab

Designed to help guide the boards and fit them together.

Positioning stops

Ensure extremely fast, precise application of the fastening, to be screwed to the board.

Joist protective cover

Covers the entire joist at the spaces between boards, to protect it from water and conceal it.

Identification of parts

In order to make installation easier and avoid mistakes, each component is identified by an engraved number (1, 2, 3 and 4) and/or its role (START/END).

Durable, rugged reinforced material

Glass-fibre reinforced material to ensure rigidity and strength, as well as durability and UV-resistance. Discreet, anti-reflective black finish.

Hole for screwing in the fastening

For screwing the fastening to the joist.

System for wood ventilation

A means to separate the boards, combined with plenty of cut-outs and openings in the fastening it-self to ensure full ventilation of the underside of the boards and the upper surface of the joists.

Patent pending

Screw shaft with guide

Designed for inserting and guiding the pre-drilling step drill bit (supplied). Chamfer for holding the screw head.

A2 AISI 304 stainless steel screw

SPAX® A2 stainless steel screws supplied in every kit.

Step drill bit for pre-drilling

Supplied in every pack. The step drill bit is specially designed to ensure the correct drilling depth, automatically, with no risk of drilling through the board.





Click on the photo to watch the video

USE

EASY TO FIT, FROM THE FIRST TO THE LAST BOARD

The Roots fastenings are supplied with accessories designed to make it easy to fit the boards, from the first to the last one. All the parts and fastenings are easy to identify by the large, clear markings engraved on the material.

With tropical species, pre-drilling is required, so a step drill bit with stop has been designed to avoid drilling through the board, while providing the pre-drilling needed for the length of the screw.



Start piece (START)

The starting piece, identifiable by the word START engraved on it, has a lateral overhang of 10 mm as required by the standard NF DTU 51.4. It is designed for holding the fastening for the first board.



Fastening the first board

Fixing for the first board supplied in every pack, is designed to be completely embedded in the starting piece (START), thus ensuring it is in exactly the right position.



End piece (END)

The end piece, identifiable by the 4-END engraved on it, allows the final board, up to 70 mm wide, to be fitted easily. It ensures a lateral overhang of 10 mm as required by the standard NF DTU 51.4.



Step drill bit with stop

The fixed stop, pre-drilling bit is specially designed to avoid drilling through the board, and ensure quick installation, compliant with requirements for pre-drilling boards. It is made of shaped, ground HS steel.

USE*	TROPICAL WOOD	RESINOUS WOOD	ACCOYA®	KEBONY®	HEAT-TREATED	BAMBOO
Minimum permitted thickness of boards	21 mm	26 mm	20 mm	20 mm	20 mm	20 mm
Residential	✓	✓	✓	✓	✓	✓
Public / Commercial	✓	✓	✓	✓	✗	✓
Coastal	✓	✓	✓	✓	✓	✓
Decking	✓	✓	✓	✓	✓	✓
Pool beaches	✓	✓	✓	✓	✓	✓

* Comply strictly with the conclusions and recommendations of FCBA product evaluation folders (see COMPLIANCE), as well as the requirements for the chosen species (NF B 54-040), the requirements of current standards and regulations (especially NF DTU 51.4), fitting instructions supplied, professional standards and good practice. For more information, contact your dealer or timber merchant, or write to us at info@novlek.com.

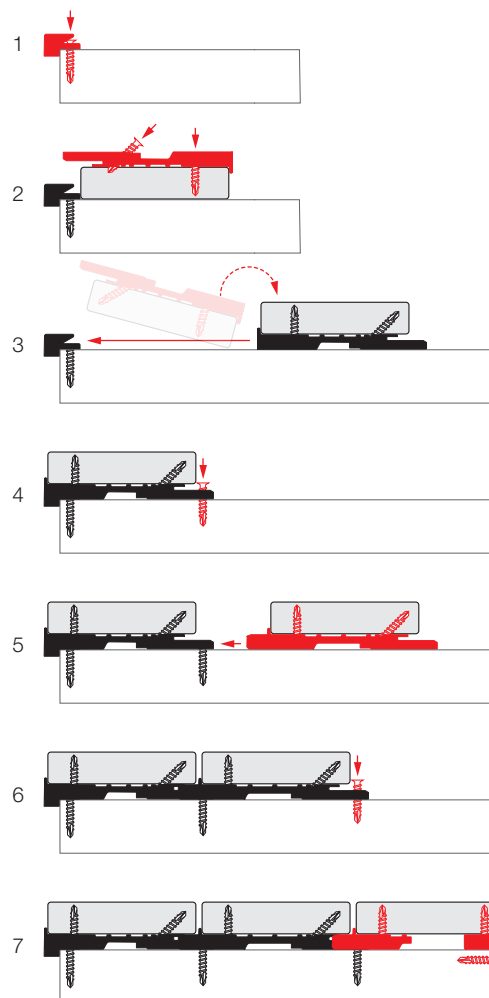

EASY DISMANTLING AND REASSEMBLY

If necessary, the decking is easy to dismantle and refit. The fastenings can be recovered for re-use, or to install further boards.

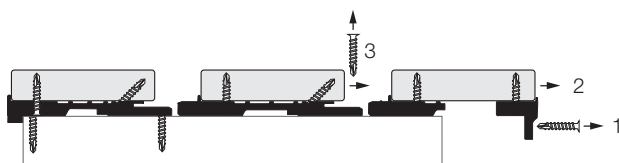

EASY REPLACEMENT OF A BOARD AFTER INSTALLATION

It is very easy to replace one or more boards locally without having to dismantle all the boards in order to do so. The installation instructions supplied in every pack provide a detailed description of each stage, from removing the board to be replaced up to installing the new board.

HIDDEN FASTENERS FOR STANDARD BOARDS



FLIP & FIX

2 STEPS FOR EASY INSTALLATION

The Roots fastenings are easy to install. They need only 2 successive, repeated operations, **flip & fix**.

The fastenings are screwed under the boards. They are then screwed onto the joist in the usual way, on one side of the fastening. The other side is held by a system similar to a "tongue-and-groove" process, with the adjacent fastening.



1. Flip & Fix

Flip the board over so the lower surface faces upwards. Screw the Roots fastening to the board.



2. Flip

Turn the board over and insert it into the adjacent fastening.



3. Fix

Screwing the Roots fastening in the normal way onto the joist.



PROTECTION

ROOTS INCREASES THE LIFE OF THE DECKING

Increasing the life of decking is achieved by improving its design to reduce the areas that retain water. In general, the more water is drained at all points and the more the wood (boards, joists) is ventilated, including on the underside, the better the life expectancy of the decking.

The NF DTU 51.4 standard addresses this issue by defining six design requirements to be met in order to achieve this objective (so-called "improved design").

Roots fasteners meet two of the requirements of improved design: they automatically create a spacer greater than 3mm between boards and joists to ensure effective ventilation and they force systematic double joisting for the joints at the end of the boards to allow more efficient water drainage. In addition, protection of the joist between the boards is provided by capping formed by the interlocking system of two adjacent fastenings.

With these features, the Roots fastenings significantly improve the lifespan and stability of the decking over time and reduce any risk of the boards cupping.

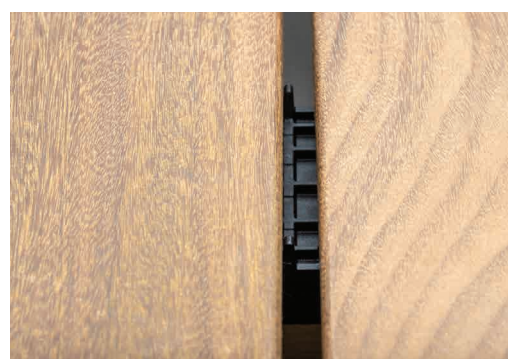
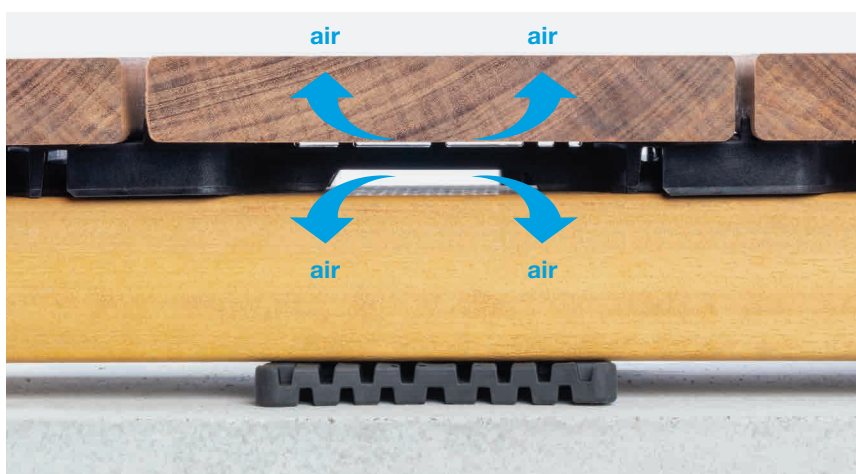

Protection for the joist is provided by capping formed by the interlocking system of two adjacent fastenings, which fully covers the joist where the boards are spaced apart and conceals it completely.

ROOTS IS THE IDEAL PARTNER FOR THE SEASIDE

All Roots A2 stainless steel screws are positioned underneath the boards which means they are fully protected and isolated from contact with salty, corrosive and aggressive environments.

COMPLIANCE - STABLE AND MODERATELY STABLE TROPICAL AND RESINOUS BOARDS

DTU 51.4 FASTENING REQUIREMENTS FOR DECKING BOARDS

The Roots hidden fastening system has had a technical evaluation by the FCBA confirming its compliance with the requirements of the standards NF DTU 51.4 and NF B54-040 regarding decking board fastenings.

Resistance to tearing: FCBA-2019.175.2230
Stability performance: FCBA-2020.175.3290

Roots fastenings fully comply with the various acceptability thresholds and criteria specified in NF DTU 51.4 and NF B54-040 for use with stable and moderately stable tropical and resinous boards.

Improved design according to standard NF DTU 51.4

The Roots fastenings meet two of the improved design criteria specified in standard NF DTU 51.4:

- insertion of a shim, at least 3 mm thick, between the decking board and the joist
- systematic use of double joists at the join between the ends of boards laid end-to-end



HIDDEN FASTENERS

FOR STANDARD BOARDS



CHARACTERISTICS

Acceptable board width	140-145 mm
Fastener thickness	13,50 mm
Material	Polypropylene and fibre glass
Colour	Black, anti-reflection
UV resistance	Yes
Resistance to high and low temperatures	Excellent
Screws supplied	SPAX® Stainless steel A2 AISI 304
Accessories supplied	Start piece, end piece, first board fastener, step drill bit with stop, torx-bit





HIDDEN FASTENERS FOR STANDARD BOARDS



Click on the photo
to watch the video

Roots

SPECIES ACCEPTABLE FOR THE ROOTS FASTENING SYSTEM TROPICAL AND MODIFIED WOOD

The withdrawal resistance and stability tests performed by the FCBA on several decking configurations combining boards and joists, tropical woods, with the Roots fastening system, made it possible to establish a list of acceptable species whose use with Roots fixings meets the criteria and requirements of the two reference standards for construction of exterior decking, the NF DTU 51.4 and NF BS 54-040.

Roots

Tropical species acceptable for use with the Roots fasteners**				
Species (without sapwood)	Drying	Stability	Acceptable board width	Minimum accepted thickness for a board width of 145 mm ***
Bangkirai	KD	MS	140 - 145 mm	min. 21 mm*
Cumaru	KD	MS		min. 21 mm
Doussié	AD/KD	S		min. 21 mm
Ipe	AD/KD	S		min. 21 mm
Itauba	AD/KD	MS		min. 21 mm*
Kapur	AD/KD	MS		min. 24 mm
Merbau	AD/KD	S		min. 21 mm
Moabi	AD/KD	MS		min. 24 mm
Padouk	AD/KD	S		min. 21 mm
Teck	AD/KD	S		min. 21 mm

S = Stable / MS = Moderately Stable

The requirements of standard NF DTU 51.4 and NF B54-040 must be respected.

* Good demonstrable performance in stability tests carried out by the FCBA (FCBA No. 2020.175.3290).

** Only stable and moderately stable species, as stated in NF B 54-040 are permitted, with the specified overhangs, except for Bangkirai and Itauba (see * above). The Roots fastening system is not suitable for use with less stable species.

*** Thickness measured at the target humidity level of 20%, according to NF B54-040.

Modified wood acceptable for use with Roots fastener			
Modified wood (Not handled by NF DTU 51.4, except Accoya®)	Stability	Acceptable board width	Minimum accepted thickness with the Roots fasteners
Accoya®	S	140 - 145 mm	min. 20 mm
Kebony®	S		min. 20 mm
Heat-treated wood (ash, pine, etc.)	S		min. 20 mm
Bamboo	S		min. 20 mm





Click on the photo to watch the video

SPECIES ACCEPTABLE FOR THE ROOTS FASTENING SYSTEM

RESINOUS WOOD

The Roots model designed specifically for the combination of softwood boards and joists has been developed to match perfectly the characteristics and properties of these species with their extremely soft and spaced fibres and much lower density than tropical species.

In this configuration, in order to be able to withstand the required withdrawal forces of at least 100 daN and to guarantee sufficient stability as demanded by the NF DTU 51.4 standard, the Roots for Resinous wood fastener has three screwing points under the boards (compared with two for Roots for Tropical wood) and a SPAX® stainless steel screw with a greater length and diameter (5x35 against 4.5x30 for Roots for Tropical wood).

The withdrawal resistance and stability tests performed by FCBA on several decking configurations combining boards and joists made from resinous species with the Roots fastening system made it possible to establish a list of acceptable species whose use with Roots fixings meets the criteria and requirements of the two reference standards for construction of exterior decking: the NF DTU 51.4 and NF B 54-040.

Roots

Resinous species acceptable for use with the Roots fasteners**					
Species	Suitable for usage classes		Stability	Acceptable board width	Minimum accepted thickness
	3.2	4			
Douglas	yes	no	MS	140 - 145 mm	min. 26 mm
Larch	yes	no	MS		min. 26 mm
Treated pine for use in class 4	yes	yes	MS		min. 26 mm

S = Stable / MS = Moderately Stable

The requirements of standard NF DTU 51.4 and NF B54-040 must be respected.

ROOTS AND IMPROVED DESIGN

During the validation tests, FCBA confirmed that the principle of Roots fasteners meets two criteria of the NF DTU 51.4 standard: they form a spacer greater than 3mm between boards and joists, and the principle allows systematic double joisting for the management of joints at the ends of the boards.

That is why Roots fasteners provide an ideal solution for exposed Douglas fir or larch decking.

Even when treated, these two species in natural usage class 3.2, are not compatible with use requiring usage class 4, unless an improved design is used, as specified in DTU 51.4 (6 criteria to be respected).



HIDDEN FASTENERS FOR STANDARD BOARDS

TROPICAL AND MODIFIED WOOD



CONTENTS

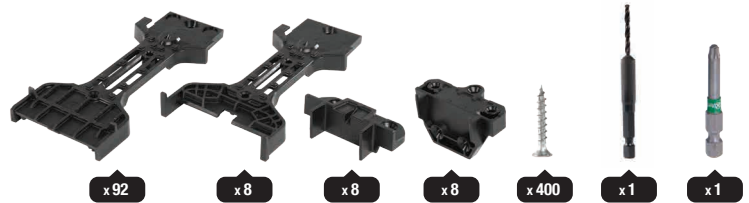

Roots

140 -145 mm boards | ± 6 m²

Estimate based on board width of 140 mm and joists centre to centre distance of 45 cm

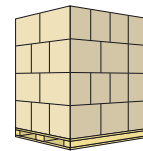

Model	Article code	EAN code	Kit		Palet 50 Kits/Palet	
			Dimensions (mm)	Weight	Dimensions (mm)	Weight
140-145	RTS-0145-100-01	5425 03355 080 6	510 x 360 x 175	6,50 kg	1200 x 1000 x 1900	350 kg



FCBA N° 2019.175.2330
FCBA N° 2020.175.3290



HIDDEN FASTENERS FOR STANDARD BOARDS

RESINOUS WOOD



CONTENTS

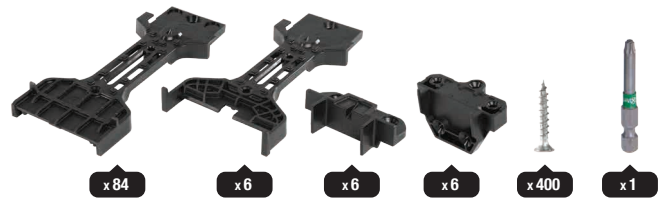

Roots

140 -145 mm boards | ± 5 m²

Estimate based on board width of 140 mm and joists centre to centre distance of 45 cm

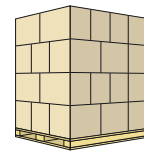
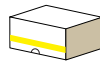

Model	Article code	EAN code	Kit		Palet 50 Kits/Palet	
			Dimensions (mm)	Weight	Dimensions (mm)	Weight
140-145	RTS-0145-090-02	5425 03355 081 3	510 x 360 x 175	6,50 kg	1200 x 1000 x 1900	350 kg



FCBA N° 2019.175.2230
FCBA N° 2020.175.3290





CONNECTORS FOR DECK TILES

Square Clip™

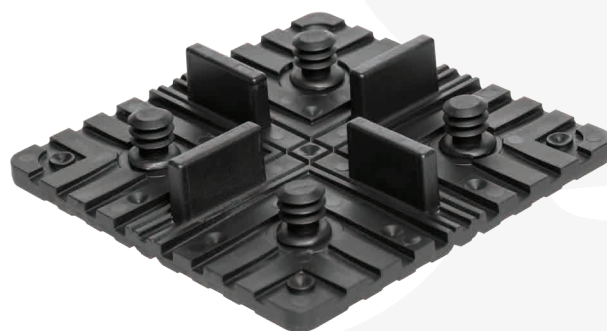

CONNECTORS FOR DECK TILES

BENEFITS



QUICK AND EASY TO INSTALL AND DISMANTLE



TILES FIXED TO EACH OTHER



REUSABLE AFTER DISMANTLING



WATER DRAINAGE SYSTEM



AUTOMATIC, EVEN SPACING OF TILES



ABSORBS THE NATURAL MOVEMENT OF THE WOOD



COMPLETELY INVISIBLE



EXCEPTIONAL MECHANICAL STRENGTH



EXTREMELY DURABLE

Installation template

The base of the connector (without the nipples) acts as a template for placing and drilling the fastener holes on the underside of the tile at the 4 corners.



Removable elastomeric assembly nipple

Fir tree shaped fastening clip, designed to absorb the natural movements of the wood. This fixes the connector firmly to the tile. Allows tiles to be removed.

Cutting guides

The connector can easily be cut into 2 or 4 pieces for exterior edges and decking corners.



1/2 connector with spacer shims



1/4 connector without spacer shims

Channels for discharging water and for ventilation

Many oriented channels with 2-3% slope cover the surface of the connector, in order to provide efficient drainage of water, and ventilation for the tile.

This avoids any risk of water being trapped on the connector. The tiles stay perfectly dry, giving them a longer lifespan.

Screw markings

The connector can be screwed to its support to prevent any risk of movement. There are 17 screw markings distributed across the entire surface.

Spacer and placement shims

Ensures automatic, even and consistent spacing of 5 mm between tiles.



Base of connector

Manufactured from high-performance polypropylene to ensure outstanding compression resistance.

Channels for discharging water

Many oriented channels cover the underside of the Square Clip™ to ensure run-off and discharge of water between the connector and the ground.

Rounded edges

The edges on the underside of the connector are rounded, to avoid piercing the supporting surface.



Click on the photo to watch the video

USE

Easy to install and to dismantle, the Square Clip™ allows the assembled decking or flooring tiles to be endlessly reorganised and rearranged. The tiles are fixed firmly to each other, with no risk of shifting.



The Square Clip™ connector can be placed or screwed directly onto the support structure (concrete floor, joists, pedestals, etc.) A tile can be removed without having to dismantle the whole layout, and without damaging the connector.



Installation template

The base of the Square Clip™ acts as a template for placing and drilling the holes in order to install the connectors on the underside of the tile at the 4 corners. Some manufacturers offer pre-drilled tiles.



Putting nipples in place in the base

The nipples simply clip into the base. They are designed to be easy to clip but difficult to unclip, so that they do not come out when they are put in place in the tile.



Installation of the connector

The fir tree shape of the elastomer nipples ensures quick and easy installation with the connector held tightly and firmly in the tile.



The tiles are isolated from the ground

The Square Clip™ keeps the tiles isolated from the ground or from their support, so they are never in prolonged contact with water or moisture. Square Clip™ guarantees greater stability and longevity.

EVEN, CONSISTENT SPACING

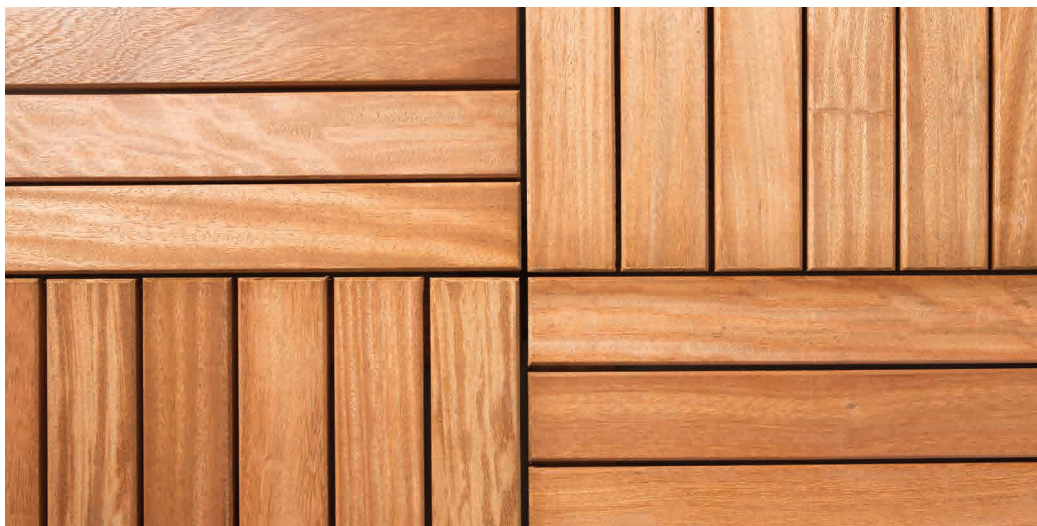

The Square Clip™ connector is completely invisible. The integrated spacers can be cut so that nothing protrudes around the outer edge.

CONNECTORS FOR DECK TILES

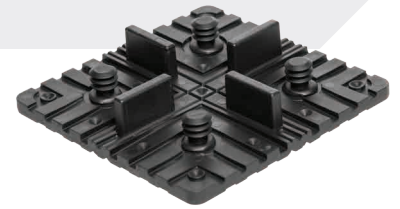

CONTENTS

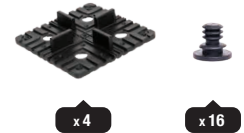

Square Clip™

4 pieces | ± 1 m²

Deck tiles: 50 cm x 50 cm

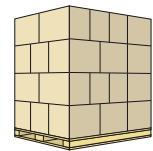

Model	Article code	EAN code	Bag		Box 30 Bags/Box		Pallet 1080 Bags/Pallet	
			Dimensions (mm)	Weight	Dimensions (mm)	Weight	Dimensions (mm)	Weight
PP	SQ-04-01	5425 03355 060 8	177 x 45 x 260	0,24 kg	395 x 260 x 400	7,57 kg	1200 x 800 x 1750	298 kg



The information shown in this document is given for information purposes and is not contractual. It may be changed at any time without prior notice. All rights reserved ARCHIWOOD sprl.

CONNECTORS FOR DECK TILES

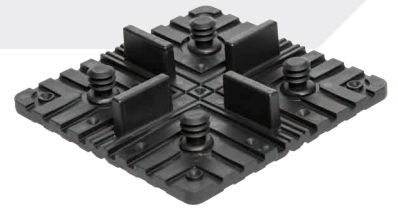

CONTENTS



x 40



x 160

Square Clip™

40 pieces | ± 10 m²

Deck tiles: 50 cm x 50 cm

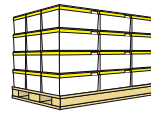

Model	Article code	EAN code	Bucket		Pallet 72 Buckets/Pallet	
			Dimensions (mm)	Weight	Dimensions (mm)	Weight
PP	SQ-040-01	5425 03355 062 2	390 x 240 x 205	2,72 kg	1200 x 800 x 1710	221 kg



CONNECTORS FOR DECK TILES

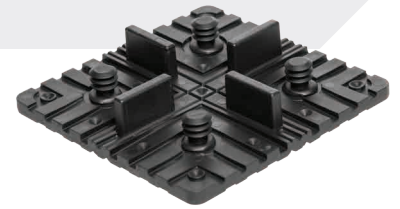

CONTENTS

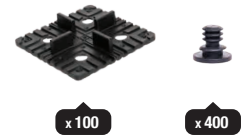

Square Clip™

100 pieces | ± 25 m²

Deck tiles: 50 cm x 50 cm

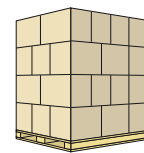

Model	Article code	EAN code	Box		Pallet 36 Boxes/Pallet	
			Dimensions (mm)	Weight	Dimensions (mm)	Weight
PP	SQ-100-01	-	395 x 260 x 240	5,84 kg	1200 x 800 x 1110	235 kg



The information shown in this document is given for information purposes and is not contractual. It may be changed at any time without prior notice. All rights reserved ARCHIWOOD sprl.



SPAX® 4X45 STAINLESS STEEL SCREWS A2

CUT T15



BENEFITS



STAINLESS STEEL A2
AISI 304



UNCOMPROMISING QUALITY
AND PERFORMANCE



MADE IN GERMANY

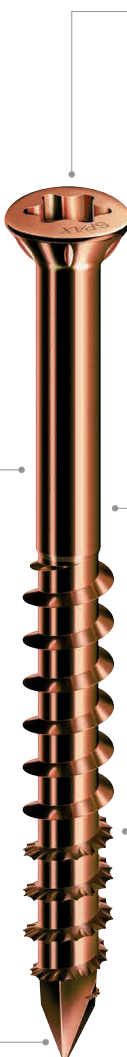

Smaller head size
Combines greater mechanical strength with maximum discretion.
Braking flanges.

Stainless steel A2
High quality stainless steel.
Very resistant to salt spray.
Anti-friction coating.

CUT point
Very accurate placement of the screw, quick to begin cutting into the wood fibres.
Allows screwing without a starter hole (comply with current standards and the instructions for the equipment used).
Effectively reduces splicing of the wood.

T-STAR PLUS
Optimal fitting of the bit and better guidance.
Very precise adjustment.
Perfect transmission of screwing torque.

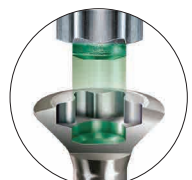

Antique finish
The stainless steel is batch-coloured.
The colour is unalterable.
Guaranteed to be discreet and offers significant reductions in reflected light or sun's rays.

Wavelike profile
Guaranteed fast, safe screw action.

T-STAR plus T15 - 50 mm bit
The SPAX Bit T-STAR plus, 50 mm long, can be clamped straight into the screwdriver chuck.
Very precise adjustment and better guidance than a 25 mm bit.



USE

The SPAX® 4x45 screw, in A2 stainless steel, is exclusive to NÖVLEK®.

It has been specially designed for the HardWood Clip® and SoftWood Clip™ invisible fasteners for timber decking and cladding. Its properties also make it an excellent, discreet screw for installing wooden cladding boards.

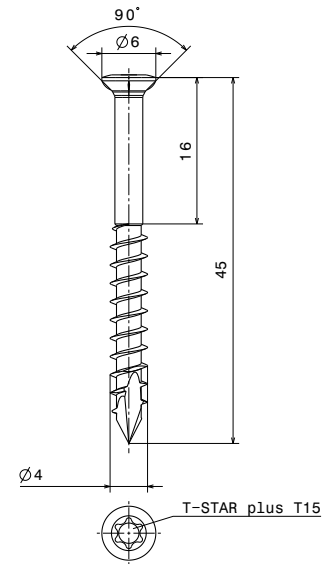

T-STAR plus T15 50 mm screw bit

To provide maximum installation convenience and to guarantee precision and efficiency in use, the SPAX® 4x45 stainless steel A2 CUT T15 screws are supplied with the T-STAR plus 50 mm screw bit.



Designed for HardWood Clip® and hardwoods

The exclusive SPAX® 4x45 stainless steel A2 screw has been designed for the HardWood Clip® invisible fastening system.

It has been certified compliant by the FCBA to meet the requirements of the NF DTU 51.4 standard for fixing planking, in combination with HardWood Clip®, to use with the hardest woods.

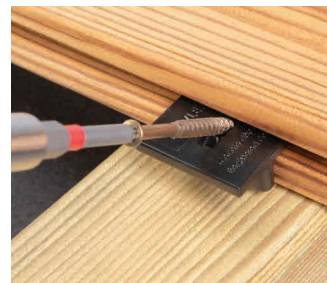

Suitable for SoftWood Clip™ and softwoods

The exclusive SPAX® 4x45 stainless steel A2 screw is the perfect match for the SoftWood Clip™ invisible fastener for soft and stable wood.



Suitable for installing wooden cladding

The SPAX® 4x45 stainless steel A2, with smaller, countersunk head and antifriction coating, is easy to screw into the wood. It provides perfect tongue-and-groove assembly. The special CUT point reduces the risk of splitting.

CERTIFICATIONS

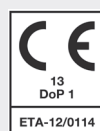

SPAX® 4X45 STAINLESS STEEL SCREWS A2 CUT T15



MADE FOR
EXCLUSIVITY
NÖVLEK



CONTENTS



Antique | 500 pieces



Model	Article code	EAN code	Box		Box 10 Boxes/Box	
			Dimensions (mm)	Weight	Dimensions (mm)	Weight
4 x 45	SPX-04045-TX-03	4003 53024 371 4	160 x 95 x 80	1,40 kg	485 x 170 x 170	14,00 kg

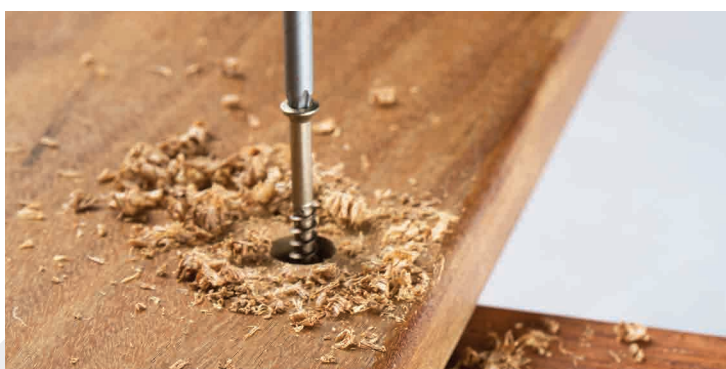
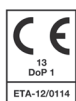

The information shown in this document is given for information purposes and is not contractual. It may be changed at any time without prior notice. All rights reserved ARCHWOOD sprl.



SPAX® 4X45 STAINLESS STEEL SCREWS A2 CUT T15



CONTENTS



Fasteners and connectors

Antique | 100 pieces



Model	Article code	EAN code	Box		Box 10 Boxes/Box	
			Dimensions (mm)	Weight	Dimensions (mm)	Weight
4 x 45	SPX-04045-TX-01	4003 53018 287 7	95 x 50 x 80	0,30 kg	270 x 210 x 90	3,00 kg

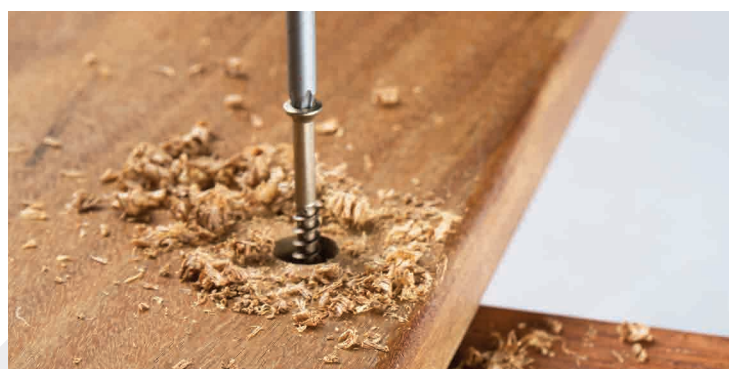
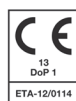

The information shown in this document is given for information purposes and is not contractual. It may be changed at any time without prior notice. All rights reserved ARCHWOOD sprl.







Protection and shimming



BITUMINOUS STRIPS

FOR JOISTS AND BEAMS

BENEFITS



OVERHANGING UMBRELLA EFFECT FOR DISCHARGING WATER



RETAINS ITS SHAPE IN THE HEAT



POLYESTER REINFORCEMENT TEARPROOF



COMPLETELY WATERPROOF



MAXIMUM SOUND INSULATION



SHOCK-ABSORBING GREATER COMFORT



EXCEPTIONAL COMPRESSION RESISTANCE



EXTREMELY DURABLE 30+ YEAR LIFESPAN



UNCOMPROMISING QUALITY AND PERFORMANCE

Flexible waterproof membrane

Composed of a polyester reinforcement covered by modified SBS elastomeric bitumen.



CE

Installed using staples

Quicker to install, no waste. Can be removed without damage and reused if necessary. No use-by date or storage conditions to be observed, since there is no glue. Can be laid no matter what the surface condition of the joists.

2 widths

Available in 2 widths: 80 mm and 100 mm, depending on the type of support to be protected (joists, beams or rafters).

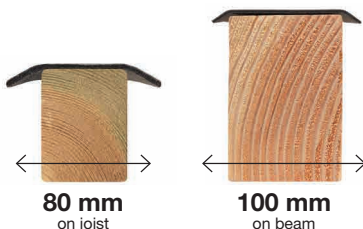

Elastomeric bitumen

The bitumen creates a perfect barrier between the board and the joist, with a waterproof seal between them. When it is drilled, the bitumen closes around the staples and fastening screws, ensuring a perfect seal.

Polyester reinforcement

The strip keeps its shape, is tearproof and extremely durable, even in high temperatures. Its composition gives it exceptional strength, but still ensuring it is flexible, making it easy to lay.

2.4 mm thick

For maximum shock-absorption and resilience.

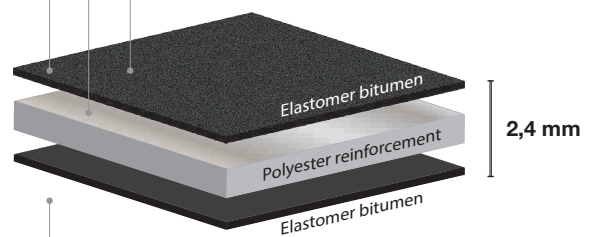

Resistance to heat	
Creep (EN 1110)	$\geq 110^{\circ}\text{C}$
Cold bending (EN 1109)	$\leq -20^{\circ}\text{C}$
Tensile strength (EN 12311-1)	
Longitudinal	700 N
Transverse	550 N
Elongation at break point (EN 12311-1)	
Longitudinal	40 %
Transverse	40 %
Nail tear strength (EN 12310-1)	
Longitudinal	130 N
Transverse	120 N

USE

The NÖVLEK® bituminous strip protects the upper surface and sides of the joist from water. Because it is waterproof, water runs off and is discharged easily. It prevents run-off water penetrating the many cracks and splits in the wood, which appear after a while, especially around screw holes.

It avoids wood-on-wood contact, and also any rising damp.

Using the NÖVLEK® bituminous strip prevents the risk of damage and premature rotting in the joists. It is strongly recommended for wooden joists with a natural durability classification greater than 1.

The bituminous strip can be used when installing decking and cladding.

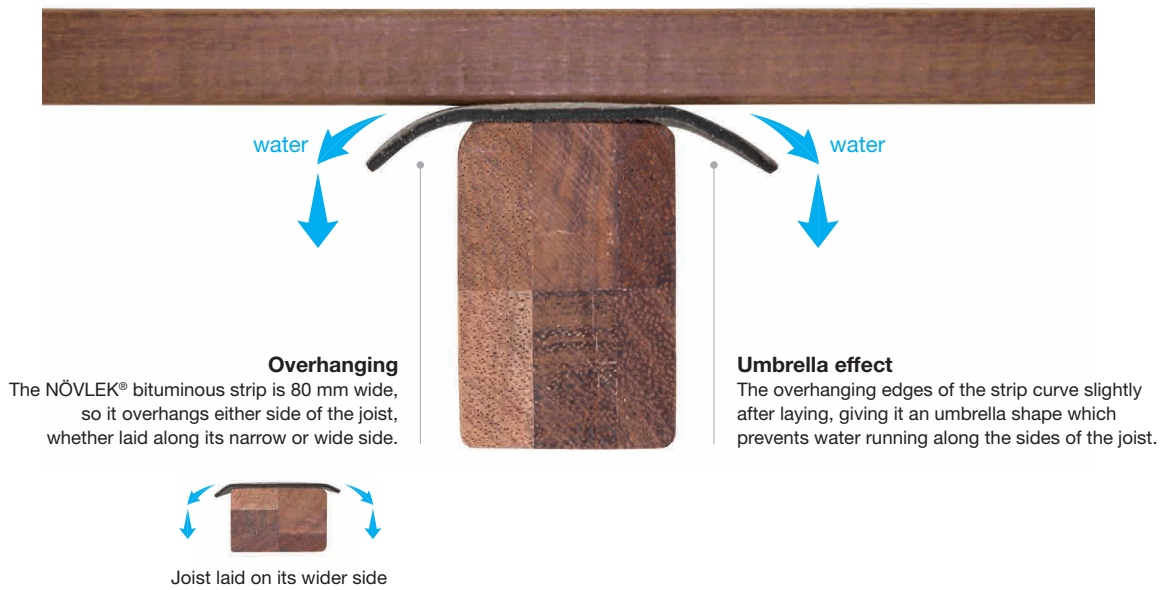

Quick and easy to lay

Some widely-spaced staples or nails are sufficient to hold it in place, before the boards are laid. The strip unrolls and aligns itself automatically on the supporting surface, thanks to its exceptional stiffness.



2.4 mm for maximum shock-absorption

The composition of the strip and its 2.4 mm thickness give it outstanding absorbent and shock-absorbing qualities, ensuring unbeatable comfort.



Additional to the ventilation interface shim

The bituminous strip protects the joist, while the ventilation shim ensures the underside of the boards is ventilated by separating them from the joist. Both guarantee durability of the decking

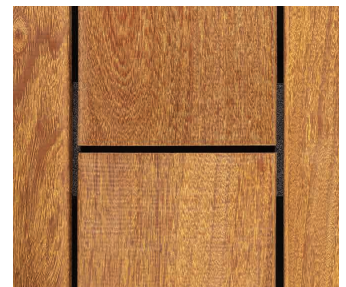

The joist is no longer visible

The bituminous strip conceals the joist completely in the spaces between boards.

COMPLIANCE

NÖVLEK® bituminous strip complies fully with the requirements of the NF DTU 51.4 standard as regards protection of the upper surface of the joists.

DTU 51.4 Requirements for protecting the upper surface of the joist (extract)

5.2.3 Type of decking with improved design (known as "medium" according to FD P 20-651)

c) Interface between board and its linear support: For a wooden joist providing linear support, the upper surface of the joist must be protected (**overhanging bituminous strips** or capping). This provision is not necessary for timber joists with durability class 1 according to standard NF EN 350 or with a durability treatment applied which is compatible with usage class 4 according to NF EN 335.

BITUMINOUS STRIPS

FOR JOISTS AND BEAMS



New!
100 mm

16m | ± 5m²

Estimate based on a basic structure

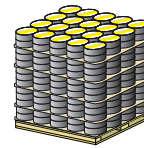

Model	Article code	EAN code	Roll		Pallet 260 Rolls/Pallet	
			Dimensions (mm)	Weight	Dimensions (mm)	Weight
80 mm	BITU-08016-01	5425 03355 200 8	Ø 225	3,30 kg	1200 x 1000 x 1210	883 kg

Model	Article code	EAN code	Roll		Pallet 220 Rolls/Pallet	
			Dimensions (mm)	Weight	Dimensions (mm)	Weight
100 mm	BITU-10016-01	5425 03355 201 5	Ø 225	4,30 kg	1200 x 1000 x 1270	971 kg



CE



The information shown in this document is given for information purposes and is not contractual. It may be changed at any time without prior notice. All rights reserved ARCHIWOOD sprl.



Protection and shimming

VENTILATION SHIMS

BENEFITS



COMPLETE VENTILATION OF THE WOOD
ELIMINATES WATER RETENTION AREAS



PROTECTION OF THE JOIST
WITH FULL CAPPING



QUICK AND EASY TO INSTALL
POSITIONING STOPS



COMPLETELY WATERPROOF
NON-POROUS MATERIAL



JOIST COVERED AND INVISIBLE



STACKABLE
SHIMMING AND LEVELLING



EXCEPTIONAL COMPRESSION
RESISTANCE



EXTREMELY DURABLE



UNCOMPROMISING QUALITY
AND PERFORMANCE

Positioning stops
They ensure extremely fast, precise installation. The shim is simply slipped between the board and the joist, up to the stops. No need to screw.

Exclusive design
The unique shape of the shim gives a maximum area of support for the board. Registered design.

5 mm thick
To ensure optimum detachment of the board from its support.

Joist protective cover
Covers the full width of the joist and protects it from water. Helps with water run-off and discharge.

Cutting guide
Ventilation shims can be split into 2 halves along the cutting guide.

Ventilation channels
Allows ventilation of the upper surface of the joist. Prevents water retention.

Durable, rugged composite material
Ensures long-term resistance to loads and stresses.

Start and end shim
Without positioning stops to prevent hindering adjustment of the first deck board. Supplied with A2 SPAX® stainless steel screws.



Click on the photo to watch the video

USE



In order to reduce the risk of water and moisture being trapped between boards and joists, it is strongly recommended that the board be detached from its supporting surface using the NÖVLEK® ventilation shims.

They ensure perfect ventilation of the underside of the boards, and prevent water retention at the contact point between board and joist.

Using NÖVLEK® ventilation shims significantly improves durability and stability of the decking, and reduces the risk of the boards cupping.

The ventilation shim is simply slipped between the board and the joist.

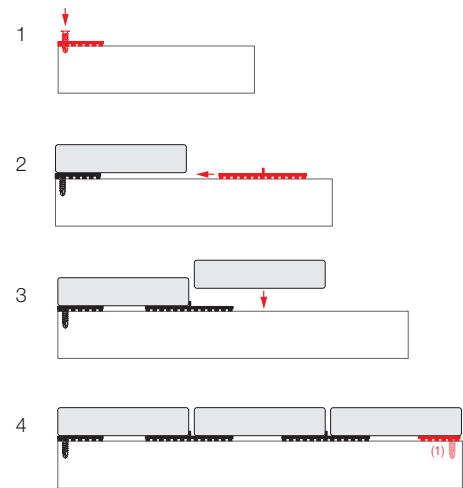

(1) end shim: installation with or without screwing



Start and end shim

The ventilation shims are supplied with start and end shims. Stainless steel screws are supplied to fix them to joists, so that they do not move when the first board is being adjusted.

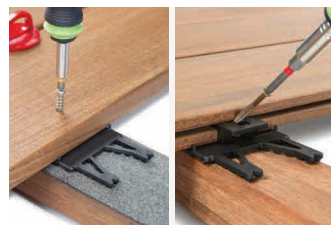

Suitable for installation with screws or invisible fasteners.

The shims are suitable both for decking installed with conventional screws from above, or with invisible fasteners.



No matter what direction the joists are laid

The shims are fitted on both the smaller or larger width of the joist.



Use as a wedge system

The shims stack and interlock to separate the joists from the ground or as a levelling shim.

COMPLIANCE

The NÖVLEK® ventilation shim complies fully with the requirements of the NF DTU 51.4 standard as regards detachment of the board from its support and for shimming.

DTU 51.4 Requirements for detachment of the board from its support and for shimming (extract)

5.2.3 Type of decking with improved design (known as “medium” according to FD P 20-651)

c) Interface between board and its linear support: To avoid water retention in the contact area between the decking board and its linear support, (polymer) shims or other separating methods **at least 3 mm thick** must be installed between the decking board and the linear support.

5.5.6.2 Fixing boards to timber supports by screws from above - 5.5.6.2.1 General points

To avoid water retention in the contact area between the decking boards and the joists, in addition to the “separating” solution of **at least 3mm**, described in the section on the improved design, it is possible to create suitable profiles on the underside of the boards or the upper surface of the joist.

General criteria for choice of materials (GCM): 4.4. Spacing devices

These shim devices are intended to form an interface between a support and a joist or a joist and a decking board. They are designed in different forms (washer, square, rectangle, etc.) They must display **high compressive resistance, durability, non-porosity** and where necessary, resilience in case of acoustic requirements.

VENTILATION SHIMS



± 12m²

90 mm

± 17m²

120 mm

± 19m²

140 mm

CONTENTS



x 300



x 25

Screws for start/end shims



x 25

x 1

± 19m²

Estimate based on board width of 140 mm and joists centre to centre distance of 45 cm

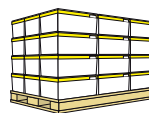

Model	Article code	EAN code	Bucket		Pallet 72 Buckets/Pallet	
			Dimensions (mm)	Weight	Dimensions (mm)	Weight
PP	INTER-0325-01	5425 03355 523 8	390 x 240 x 205	3,65 kg	1200 x 800 x 1710	288 kg



The information shown in this document is given for information purposes and is not contractual. It may be changed at any time without prior notice. All rights reserved ARCHIWOOD sprl.

VENTILATION SHIMS



- ±4m²
90 mm
- ±5m²
120 mm
- ±6m²
140 mm

CONTENTS

	Start/end shims		Screws for start/end shims
x 90	x 10	x 10	

± 6 m²

Estimate based on board width of 140 mm and joists centre to centre distance of 45 cm

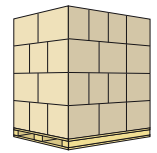

Model	Article code	EAN code	Box		Box 8 Boxes/Box		Pallet 288 Boxes/Pallet	
			Dimensions (mm)	Weight	Dimensions (mm)	Weight	Dimensions (mm)	Weight
PP	INTER-0100-01	5425 03355 522 1	245 x 190 x 95	1,14 kg	395 x 260 x 400	9,55 kg	1200 x 800 x 1750	369 kg



The information shown in this document is given for information purposes and is not contractual. It may be changed at any time without prior notice. All rights reserved ARCHIWOOD sprl.

ISOLATION SHIMS FOR JOISTS AND BEAMS

BENEFITS



WATER DRAINAGE SYSTEM



COMPLETE VENTILATION OF THE WOOD
ELIMINATES WATER RETENTION AREAS



QUICK AND EASY TO INSTALL
POSITIONING MARKS



COMPLETELY WATERPROOF
NON-POROUS MATERIAL



MAXIMUM SOUND
INSULATION



SHOCK-ABSORBING
GREATER COMFORT



EXCEPTIONAL COMPRESSION
RESISTANCE



EXTREMELY DURABLE



UNCOMPROMISING QUALITY
AND PERFORMANCE

Non-porous materials, with very high compressive resistance

Does not absorb water and moisture. Ensures complete stability, absorbing surface irregularities and ensuring good acoustic insulation.

2 thicknesses available

6 and 10 mm.

Channels for water evacuation and ventilation

Many oriented channels with 2-3% slope cover both sides of the shim to effectively remove water and eliminate any risk of water retention and stagnation on and under the shim. The deep channels also contribute to good ventilation of the underside of the joist. The joists are kept perfectly dry and their lifespan is increased.

slope 3%  slope 3%

Centring and position guides

Allow the shim to be located and centred quickly with respect to the width of the joist (markers at 40, 50, 60 or 70 mm).

Hole for screwing in the shim

Avoids shifting of the shims when adjusting the sub-structure, and over time.

Indented shape

The indented shape is designed to facilitate the flow of water between two shims placed edge to edge (as with double joists).



USE

Wooden joists must always be isolated from the ground with shim systems. They should never be placed on the ground or even directly on their support structures such as concrete blocks or ground beams.



NÖVLEK® isolation shims separate the timber joists from the ground or from their support structure and ensure they always stay dry. Using them prevents the risk of premature rotting of the joists or beams.

Guide to <u>minimum</u> thicknesses to follow	
Thickness of the spacer	Joists or beams laid on
≥ 5 mm	Linear concrete support
≥ 10 mm	Concrete block
≥ 10 mm	Concrete slab if joists are laid in the direction of the slope
≥ 20 mm	Concrete slab if joists are laid perpendicular to the slope



Increased stability and lifespan

The multiplicity of channels on the surface ensure ventilation and effective water runoff. There is no risk of water retention between shim and joist, and between shim and ground. This significantly improves stability and durability of the joists.



Stackable and combinable with each other

The isolation shims stack and combine together to the height wanted or required by standards in force.



Screwing the shim on the underside of the joist

It is recommended to screw the shims under the structure, to prevent them from moving when the joists are being adjusted during laying, or subsequently over time. Guaranteed to save time.



Placement indicators

Ensure precise positioning and very speedy installation.

COMPLIANCE

The NÖVLEK® isolation shims comply fully with the requirements of the NF DTU 51.4 standard as regards shims for the installation of joists.

DTU 51.4 Requirements for the installation of joists (extract)

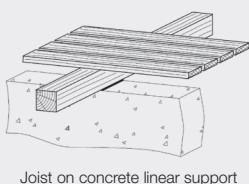
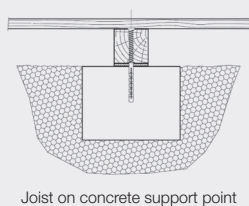
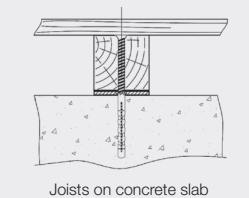

5.5.3.1. General principles (Installation of joists)

The joists must always be isolated from the ground with metal or polymer shim systems (no wooden shims, no joists laid on the ground).

Installation of the joists	On concrete slab	On concrete supports	On concrete beams
Minimum thickness of the isolation shim	Joists parallel to slope: 10 mm Joists perpendicular to slope: 20 mm	5 mm	5 mm

5.5.3.3. Installation of joists on concrete slab

The joists must be separated from the concrete slab by shims. In order to avoid the movement of the shims over time, they must always be seated in the structure (for example by attachment to the joist).

In this case (joists in the direction of the slope of the upper bare slab surface), the isolation shim thickness must be **greater than or equal to 10 mm**. Isolation shims must be **greater than or equal to 20 mm** in thickness if the joists are positioned perpendicular to the slope of the slab.

5.5.3.5.3. Joist on linear concrete supports

The shimming of the joists must be **greater than or equal to 5 mm**.

General criteria for selection of materials (GCM): 4.4. Spacing devices

These shim devices are intended to form an interface between a support and a joist or a joist and a decking board. They are designed in different forms (washer, square, rectangle, etc.) They must display **compressive strength, durability, non-porosity** and where necessary, resilience in case of acoustic requirements.

ISOLATION SHIMS FOR JOISTS AND BEAMS



25 pieces | ± 5 m²

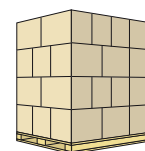

Model	Article code	EAN code	Pack		Box 20 Packs/Box		Pallet 540 Packs/Pallet	
			Dimensions (mm)	Weight	Dimensions (mm)	Weight	Dimensions (mm)	Weight
6 mm	PAD-06-25-01	5425 03355 530 6	150 x 90 x 90	0,67 kg	395 x 260 x 300	13,81 kg	1200 x 800 x 1050	398 kg

Model	Article code	EAN code	Pack		Box 12 Packs/Box		Pallet 432 Packs/Pallet	
			Dimensions (mm)	Weight	Dimensions (mm)	Weight	Dimensions (mm)	Weight
10 mm	PAD-10-25-01	5425 03355 531 3	250 x 90 x 90	1,07 kg	395 x 260 x 300	13,35 kg	1200 x 800 x 1350	505 kg



The information shown in this document is given for information purposes and is not contractual. It may be changed at any time without prior notice. All rights reserved ARCHIWOOD sprl.







Installation tools



SPACERS

BENEFITS



EXCLUSIVE "V" PROFILE
EASY TO REMOVE



1 COLOUR = 1 SIZE
ERROR-FREE



TIME-SAVING GUARANTEED



CAN BE REUSED



EXCEPTIONALLY STRONG



UNCOMPROMISING QUALITY
AND PERFORMANCE

3 mm



Perfect ergonomic design

The wide, open handle ensures a firm, effective grip for inserting and withdrawing the shim, as well as giving room for a tool to be passed through (pliers or wood chisel), if necessary.

Exclusive anti-lock profile

The V-shape and wide, hollowed sides allow the shim to be withdrawn easily.

5 mm



V profile

Ensures problem-free insertion and removal.



Wide support plate

Prevents the spacer falling between the boards.

Chamfered edge

Designed to apply a lever movement to the edge of the board, to make its removal easier.

7 mm



Non-distorting material

Exceptionally stiff and strong.

Multi-use markers

USE

The NÖVLEK® spacers ensure the correct, consistent spacing between the decking boards during installation, thus allowing good ventilation, water runoff and hygiene for the wood. This significantly reduces the risks of premature deterioration and rotting of the boards.

Spacing at the end of the boards

To ensure ventilation and hygiene of the ends of the boards.

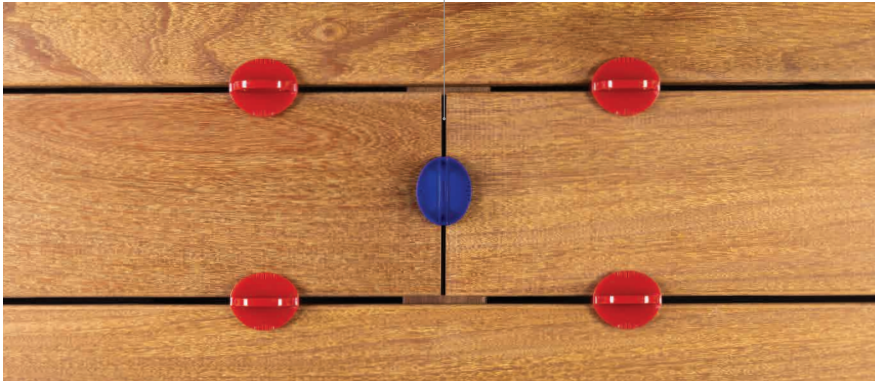

Spacing between boards along their whole length

3 thicknesses to ensure the correct spacing, depending on the timber and the humidity level of the boards during installation.



Perfectly designed shapes

The exclusive V profile, and the wide handle ensure that the NÖVLEK® spacer is easy to fit and remove.



Ready for all situations

If necessary, a tool such as a wood chisel can fit through the wide, open handle.



Exceptional strength

The exceptional strength of the handle means that significant force can be applied with no risk of breaking.



Designed to the last detail

The chamfered edge of the spacer allows a lever movement to be applied between the boards, in order to release a spacer easily.

COMPLIANCE

The NÖVLEK® spacers comply fully with the requirements of the NF DTU 51.4 standard as regards thicknesses of the shims for spacing between boards.

DTU 51.4 Requirements relating to spacing between boards (extract)



5.5.4.2.2 Spacing between decking boards



5.5.5 Continuity at the end of the board

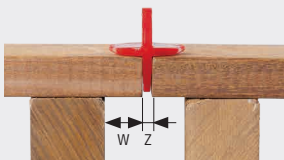

5.2.3. Spacing between two board ends

5.5.4.2.2 Spacing between decking boards

In accordance with the provisions noted in 5.5.4.2.1, the thicknesses of shims to be used for mainland France are as follows:

Moisture of boards	From 12 to 17 %	From 18 to 22 %	From 23 % and to a moisture level higher than the fibre saturation point (FSP)
Thickness of the spacer	7 mm	5 mm	3 mm

5.5.5 Continuity at the end of the board

Continuity at the end of the board is a particular point for grain-cut timber and is a weak area in terms of durability. Consequently, the gap (z) between two board ends must be **between 4 and 6 mm**. Gap of **between 1 and 5 mm** is permitted, however, for timber boards with a very high natural durability class (class 1 according to NF EN 350).

5.2.3 Type of decking with improved design (known as "medium" according to FD P 20-651)

a) Junction of ends of boards: A double-joint system allows water to run off between the ends of the boards, to ensure the hygiene of the grain-cut ends, to prevent moisture being trapped on the underside of the end.

The distance z between the ends of the boards must be **between 4 and 6 mm**, and the distance w between the end of the board and the joist between 20 and 30 mm.

SPACERS



1 size | 25 pieces

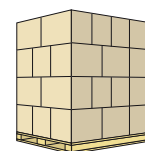

Model	Article code	EAN code	Tub		Box 3 Tubs/Box		Pallet 168 Tubs/Pallet	
			Dimensions (mm)	Weight	Dimensions (mm)	Weight	Dimensions (mm)	Weight
● 3 mm	GAP-3-25-01	5425 03355 300 5	155 x 120 x 125	0,39 kg	365 x 160 x 135	1,29 kg	1200 x 800 x 690	97 kg
● 5 mm	GAP-5-25-01	5425 03355 301 2	155 x 120 x 125	0,43 kg	365 x 160 x 135	1,41 kg	1200 x 800 x 690	104 kg
● 7 mm	GAP-7-25-01	5425 03355 302 9	155 x 120 x 125	0,49 kg	365 x 160 x 135	1,58 kg	1200 x 800 x 690	113 kg



SPACERS



3 size mix | 24 pieces

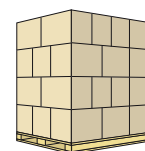

Model	Article code	EAN code	Tub		Box 3 Tubs/Box		Pallet 168 Tubs/Pallet	
			Dimensions (mm)	Weight	Dimensions (mm)	Weight	Dimensions (mm)	Weight
 8 x 3 mm 8 x 5 mm 8 x 7 mm	GAP-MX-24-02	5425 03355 303 6	155 x 120 x 125	0,43 kg	365 x 160 x 135	1,40 kg	1200 x 800 x 690	103 kg

Installation tools



The information shown in this document is given for information purposes and is not contractual. It may be changed at any time without prior notice. All rights reserved ARCHWOOD sprl.

SPACERS



1 size | 12 pieces

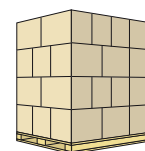

Model	Article code	EAN code	Bag		Box 20 Bags/Box		Pallet 360 Bags/Pallet	
			Dimensions (mm)	Weight	Dimensions (mm)	Weight	Dimensions (mm)	Weight
● 3 mm	GAP-3-12-01	5425 03355 314 2	150 x 30 x 230	0,15 kg	395 x 260 x 240	3,25 kg	1200 x 800 x 630	84 kg
● 5 mm	GAP-5-12-01	5425 03355 315 9	150 x 30 x 230	0,17 kg	395 x 260 x 240	3,66 kg	1200 x 800 x 630	91 kg
● 7 mm	GAP-7-12-01	5425 03355 316 6	150 x 40 x 230	0,19 kg	395 x 260 x 240	4,13 kg	1200 x 800 x 630	99 kg





The information shown in this document is given for information purposes and is not contractual. It may be changed at any time without prior notice. All rights reserved ARCHIWOOD sprl.

SPACERS

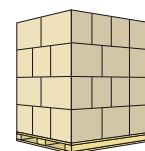

3 size mix | 12 pieces



Model	Article code	EAN code	Bag		Box 20 Bags/Box		Pallet 360 Bags/Pallet	
			Dimensions (mm)	Weight	Dimensions (mm)	Weight	Dimensions (mm)	Weight
 4 x 3 mm 4 x 5 mm 4 x 7 mm	GAP-MX-12-01	5425 03355 317 3	150 x 30 x 230	0,17 kg	395 x 260 x 240	3,68 kg	1200 x 800 x 630	91 kg

Installation tools



The information shown in this document is given for information purposes and is not contractual. It may be changed at any time without prior notice. All rights reserved ARCHIWOOD sprl.

STEP DRILL BITS FOR PLUGS

BENEFITS



CYLINDRICAL, FLAT-BOTTOMED COUNTERSINK FOR INSERTING PLUGS



DEPTH OF COUNTERSINK AND DRILLING ADJUSTABLE



GUARANTEED TO SAVE TIME 2 PROCEDURES IN ONE



CAN BE REGROUND



STEEL HSS
100 Cr6
HSS GROUND DRILL



UNCOMPROMISING QUALITY AND PERFORMANCE

Access opening to drill

Depth stop setting marker
Allows the depth of countersink to be adjusted quickly to 7mm for the plug, as recommended for NOVLEK® plugs.

Hexagonal stem
For quick change.

Tightening and adjustment screw for the stop

Depth stop moveable and adjustable
Used for precise setting of the depth of the countersink. Resin depth stop, fitted on a roller. Does not mark the surface of the boards.

Wide opening
For efficient removal of shavings.

Steel HSS 100 Cr6 countersink tool
Countersink diameter \varnothing 10 or 12 mm. Cylindrical, flat-bottomed countersink.

Blades
To cut fibres before countersinking.

HSS ground drill
Choice of 2 diameters \varnothing 3 mm and \varnothing 4 mm depending on screw diameter. Standard model for easy replacement.

Drill tightening and adjustment screw
Used to adjust the drill depth, so as to drill the board only, or the board and the joist to the full length of the screw.

Maintenance
Fully removable. Countersink bit can be resharpened.

USE

The NÖVLEK® step drill is unique. It is designed to pre-drill the screw hole and sink a flat-bottomed, cylindrical cavity into which the plug will fit. The cylindrical shape of the hole allows the plug to lock perfectly into place. The flat base ensures maximum contact area between plug and support, especially for glueing.

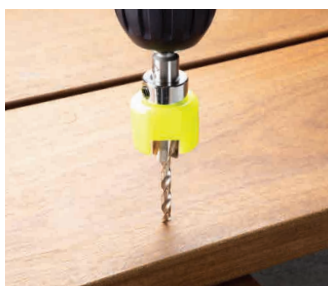
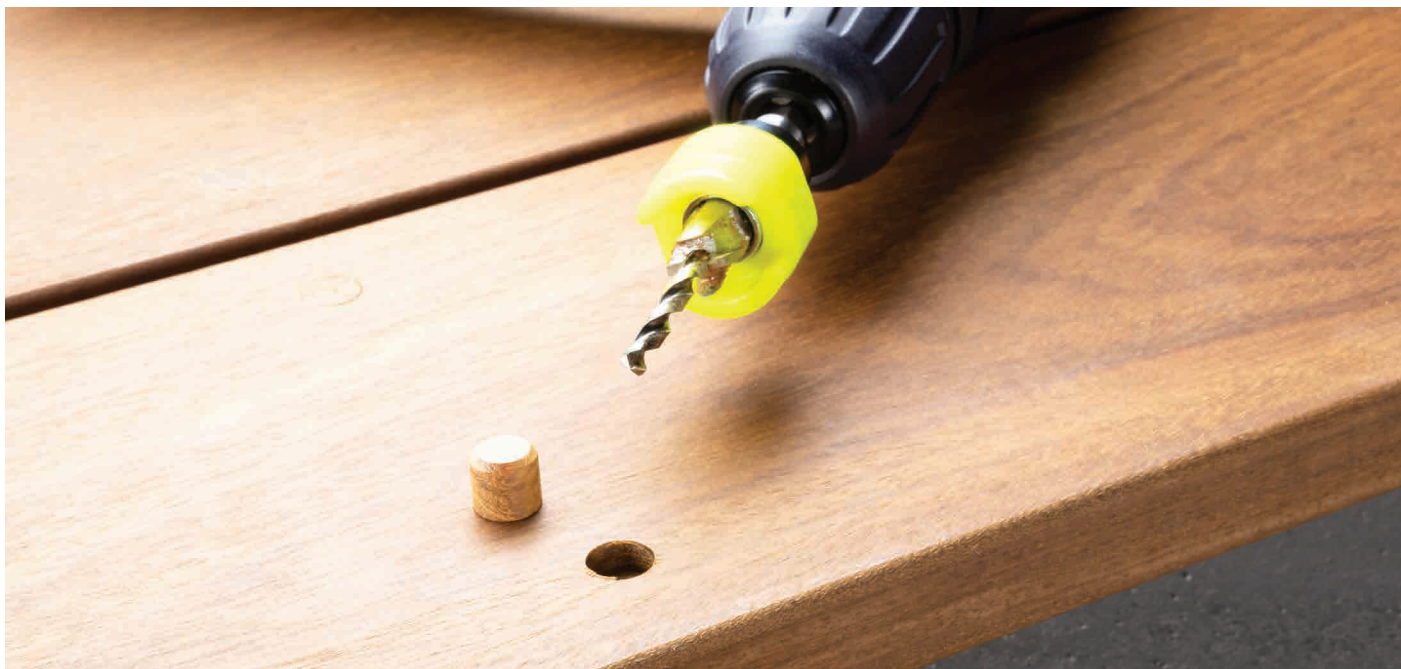

Keep the drill at 90° with respect to the surface being drilled

The drill must be held fully perpendicular (at 90°) to the surface being drilled, throughout the drilling operation, to avoid breaking it. The pressure applied to the drilling machine must also be applied in the axis of the drill bit and perpendicular to the surface being drilled.



No marks on the wood

To ensure a perfect result, hold the depth stop between two fingers to stop it rotating and avoid any shavings which are between the end stop and the board being caught and marking the surface of the wood. This ensures the shavings are completely removed during drilling.



Cylindrical, flat-bottomed hole

The step drill bit for plugs, exclusive to NÖVLEK®, is designed to drill a flat-bottomed cylindrical hole into which the plug will fit perfectly. The blades ensure a sharp, splinter-free cut in all types of timber.



Adjustment according to the job

The height of the drill can be adjusted, especially to modify the drilling depth to suit the timber being used. A board in an exotic species, laid onto a joist also in an exotic species, requires the joist and board to be drilled through for the full length of the screw. Where the same board is laid onto a joist in a resinous wood only the board needs to be drilled.

COMPLIANCE

The NÖVLEK® plug step drill bits comply fully with the requirements of standard NF DTU 51.4 for pre-drilling.

DTU 51.4 Requirements relating to pre-drilling (extract)

5.5.6.2.2 a) Pre-drilling the board

The board must be pre-drilled for all fasteners at the end of a board in resinous timber of a broad-leaved species. Pre-drilling must be done along the whole length of the board for boards from broad-leaved species.

For screws with countersunk heads, pre-drilling must be done with countersinking on the surface of the board to accommodate the screw head. When pre-drilling, the hole must be about 0,8 times the external diameter of the screw thread for double-thread screws, and of the diameter below the head for screws with partial threading.

5.5.6.2.2 b) Pre-drilling of timber support (joist or beam)

Pre-drilling must be done on the intermediate part of the support for timbers with a density of 600 kg/m³ or more.

STEP DRILL BITS FOR PLUGS



New!
 Ø 12 mm / 4 mm



CONTENTS

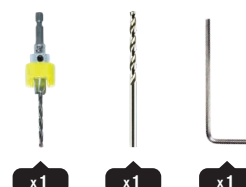

Ø	Article code	EAN code	Item		Box 12 Items/Box		Box 96 Items/Box	
			Dimensions (mm)	Weight	Dimensions (mm)	Weight	Dimensions (mm)	Weight
3 - 10 mm	DRL-03010-01	5425 03355 210 7	Ø 40 x 170	0,08 kg	245 x 190 x 95	1,14 kg	395 x 260 x 400	9,56 kg
4 - 10 mm	DRL-04010-01	5425 03355 211 4	Ø 40 x 170	0,08 kg	245 x 190 x 95	1,14 kg	395 x 260 x 400	9,56 kg
4 - 12 mm	DRL-04012-01	5425 03355 212 1	Ø 40 x 170	0,10 kg	245 x 190 x 95	1,38 kg	395 x 260 x 400	11,48 kg

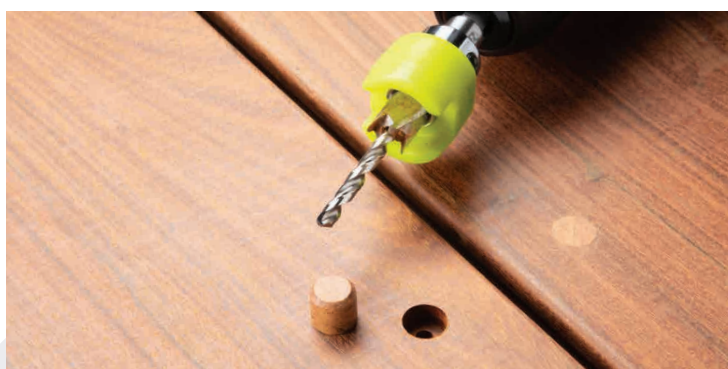

The information shown in this document is given for information purposes and is not contractual. It may be changed at any time without prior notice. All rights reserved ARCHIWOOD sprl.



Installation tools

DRILL COUNTERSINKS FOR DECKING

BENEFITS



CONICAL COUNTERSINKING FOR SCREW HEAD 90° OR 60°



DEPTH OF COUNTERSINK AND DRILLING ADJUSTABLE



GUARANTEED TO SAVE TIME



CAN BE REGROUND



STEEL HSS
100 Cr6
HSS GROUND DRILL



UNCOMPROMISING QUALITY AND PERFORMANCE

Depth stop setting markers

For quick adjustment of the depth and diameter of countersinking, depending on the screw head.

Depth stop moveable and adjustable

Used for precise setting of the depth of the countersink.
Resin depth stop, fitted on a roller.
Does not mark the surface of the boards.

Steel HSS 100 Cr6 conical countersink tool

Choice of 2 countersinking angles

60° or 90° depending on the angle of the screw head.



Drill tightening and adjustment screw

Used to adjust the drill depth, so as to drill the board only, or the board and the joist to the full length of the screw.

Access opening to drill

Hexagonal stem

For quick change.

Tightening and adjustment screw for the stop

Wide opening

For efficient removal of shavings.

HSS ground drill bit ø 4 or ø 5 mm

Overall length: 75 mm.
Standard model for easy replacement.

Maintenance

Fully removable.
Countersink bit can be resharpened.



USE

The NÖVLEK® drill countersinks for decking is designed to pre-drill the board and joist, and countersink the hole for the screw head, in one operation. Its multiple adjustments mean that the drilling can be perfectly fitted to the shape of the screw head as well to the job to be done and the timber used.

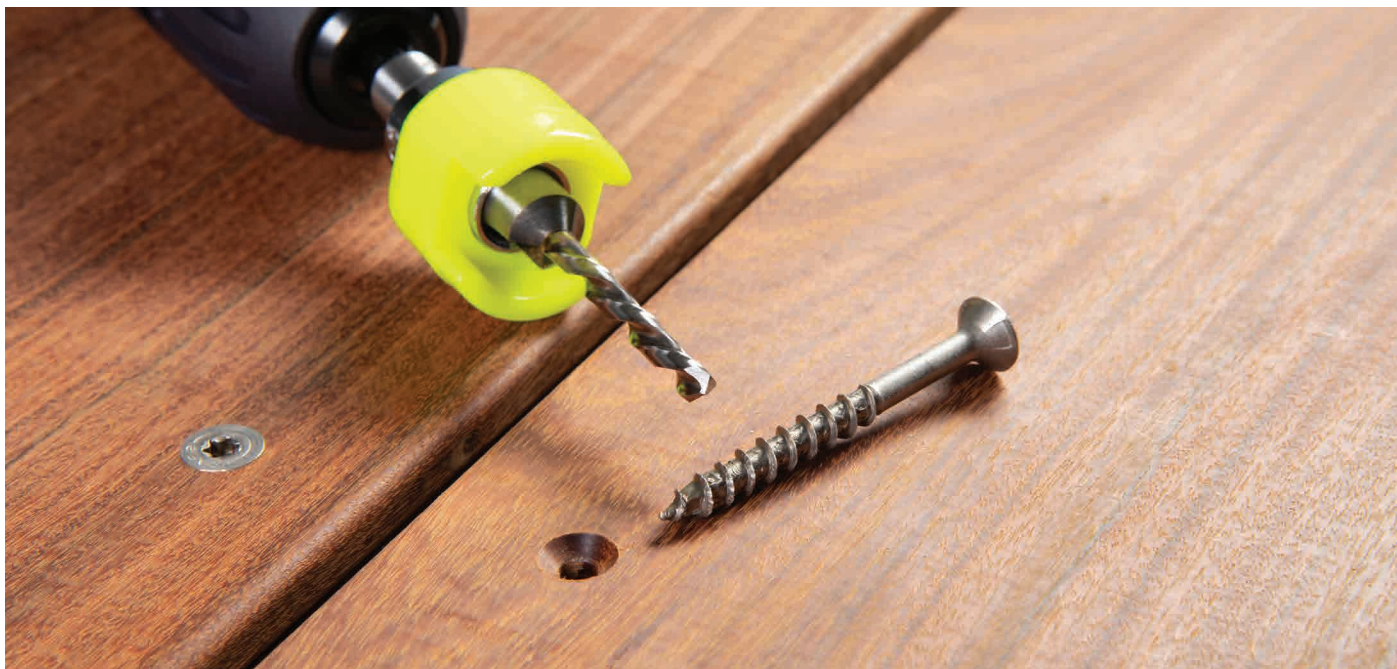

No marks on the wood

To ensure a perfect result, hold the depth stop between two fingers to stop it rotating and avoid any shavings which are between the end stop and the board being caught and marking the surface of the wood. This ensures the shavings are completely removed during drilling.



Clean, burr-free cut

Splinter-free, clean result on all types of wood.



Impeccable finish

The stop adjustment ensures precise drilling (routing / countersinking) on the board surface so that the screw head fits perfectly.



Adjustment according to the job

The height of the drill can be adjusted, especially to modify the drilling depth to suit the timber being used. A board in an exotic species, laid onto a joist also in an exotic species, requires the joist and board to be drilled through for the full length of the screw. Where the same board is laid onto a joist in a resinous wood only the board needs to be drilled.

COMPLIANCE

The NÖVLEK® decking drill countersinks comply fully with the requirements of standard NF DTU 51.4 for pre-drilling.

DTU 51.4 Requirements relating to pre-drilling (extract)

5.5.6.2.2 a) Pre-drilling the board

The board must be pre-drilled for all fasteners at the end of a board in resinous timber of a broad-leaved species. Pre-drilling must be done along the whole length of the board for boards from broad-leaved species.

For screws with countersunk heads, pre-drilling must be done with countersinking on the surface of the board to accommodate the screw head. When pre-drilling, the hole must be about 0,8 times the external diameter of the screw thread for double-thread screws, and of the diameter below the head for screws with partial threading.

5.5.6.2.2 b) Pre-drilling of timber support (joist or beam)

Pre-drilling must be done on the intermediate part of the support for timbers with a density of 600 kg/m³ or more.

DRILL COUNTERSINKS FOR DECKING



New!
60°/5 mm



CONTENTS



Angle - Ø	Article code	EAN code	Item		Box 12 Items/Box		Box 96 Items/Box	
			Dimensions (mm)	Weight	Dimensions (mm)	Weight	Dimensions (mm)	Weight
90° - 4 mm	DRL-04010-02	5425 03355 230 5	Ø 40 x 170	0,08 kg	245 x 190 x 95	1,14 kg	395 x 260 x 400	9,56 kg
60° - 4 mm	DRL-04010-03	5425 03355 232 9	Ø 40 x 170	0,08 kg	245 x 190 x 95	1,14 kg	395 x 260 x 400	9,56 kg

Angle - Ø	Article code	EAN code	Item		Box 10 Items/Box		Box 80 Items/Box	
			Dimensions (mm)	Weight	Dimensions (mm)	Weight	Dimensions (mm)	Weight
60° - 5 mm	DRL-05012-01	5425 03355 234 3	Ø 40 x 170	0,10 kg	245 x 190 x 95	1,20 kg	395 x 260 x 400	10,07 kg

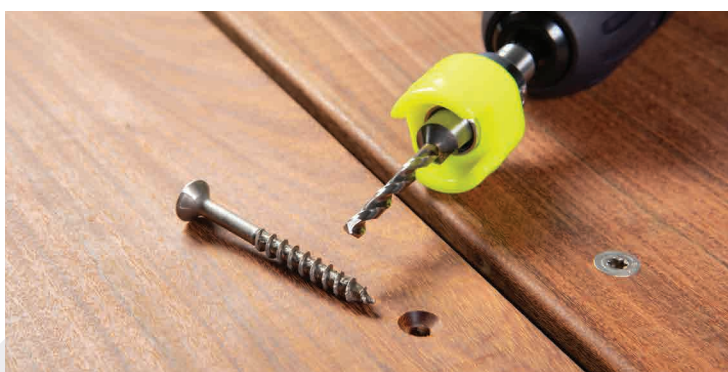

The information shown in this document is given for information purposes and is not contractual. It may be changed at any time without prior notice. All rights reserved ARCHWOOD sprl.



BOARD CLAMP

BENEFITS



ADJUSTABLE ACCORDING TO BOARD WIDTH



SELF-LOCKING ADJUSTMENT



GUARANTEED TO SAVE TIME



CAN BE USED ONE-HANDED



EXCEPTIONALLY STRONG



UNCOMPROMISING QUALITY AND PERFORMANCE

YOUR 3rd HAND®

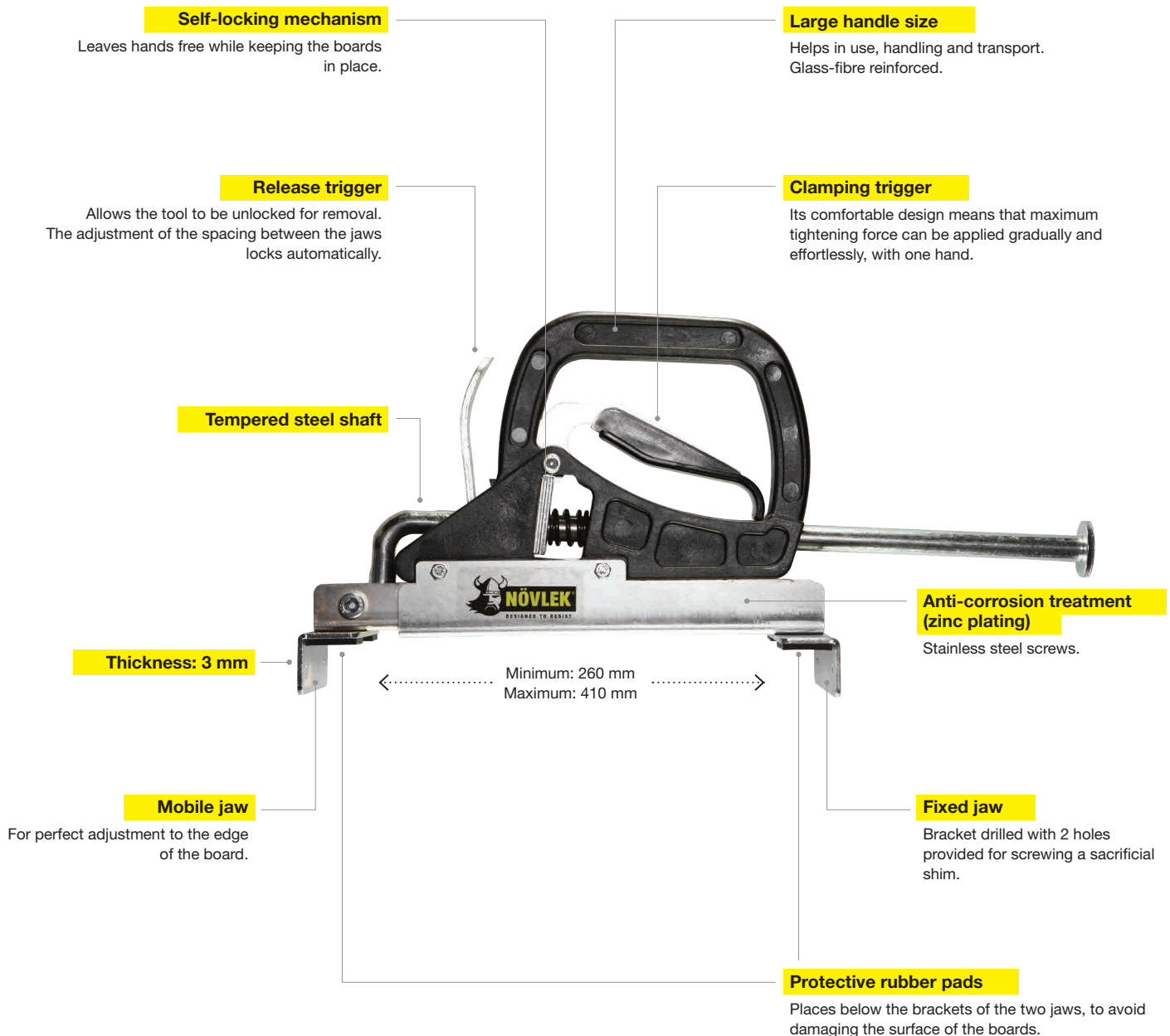

USE

Using NÖVLEK® board clamps when installing decking or cladding boards allows them to be tightened, straightened and held in place quickly and effortlessly.



Using several board clamps together significantly improves the efficiency, quality and speed of installation.

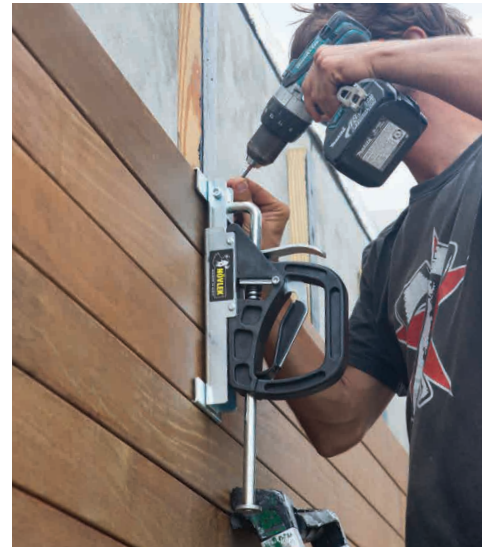

Suitable for installing cladding boards, both vertical and horizontal.



Only one hand needed

Manipulated and operated with one hand, suitable for right- and left-handed use. Gradual, effortless tightening with the comfortable trigger.



Adjusted once and for all

Tool unlocked for removal with the front trigger. The jaw spacing is adjusted and locked automatically for the entire job, saving considerable time and making it extremely easy to use.



Narrow boards

The NÖVLEK® board clamps can be used with narrow boards. In this case, a sacrificial shim is needed. It can be screwed to the jaw temporarily, with the two holes provided for this purpose.



Can be used with the DROP™ profile

A short bracket is available for use with boards having the DROP™ covering profile (from NÖVLEK®) or similar.

Why choose the NÖVLEK® board clamp, rather than a lever-arm straightener supported on the joist?

The NÖVLEK® board clamp

- Does not damage the edge of the boards, or the joists.
- Allows tightening and straightening up to the last board.
- Can be placed anywhere, alone or with several aligned side by side, when the situation requires it.
- No limit on its use
 - even in the narrowest areas or close to an obstacle;
 - on the connections and spacers between joists;
 - whatever the height, width or material of the joists or beams;
 - regardless of whether the joists are covered by overhanging bituminous strips.
- Acts only on the board, without applying any force to the joist. There is no risk of displacing or distorting the joist.
- Keeps the finishing boards in place before they are screwed.



NÖVLEK® board clamp

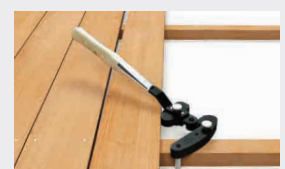

Lever-arm straightener

BOARD CLAMP



CONTENTS



x1

Only for BJPD-04



x1



x3



x3



x3



Profile	Article code	EAN code	Item		Box 5 Items/Box	
			Dimensions (mm)	Weight	Dimensions (mm)	Weight
Square edge	BJPD-01	5425 03355 400 2	450 x 120 x 365	3,83 kg	585 x 380 x 500	20,12 kg
Drop	BJPD-04	5425 03355 400 2	450 x 120 x 365	3,85 kg	585 x 380 x 500	20,22 kg



The information shown in this document is given for information purposes and is not contractual. It may be changed at any time without prior notice. All rights reserved ARCHIWOOD sprl.







Finishing products

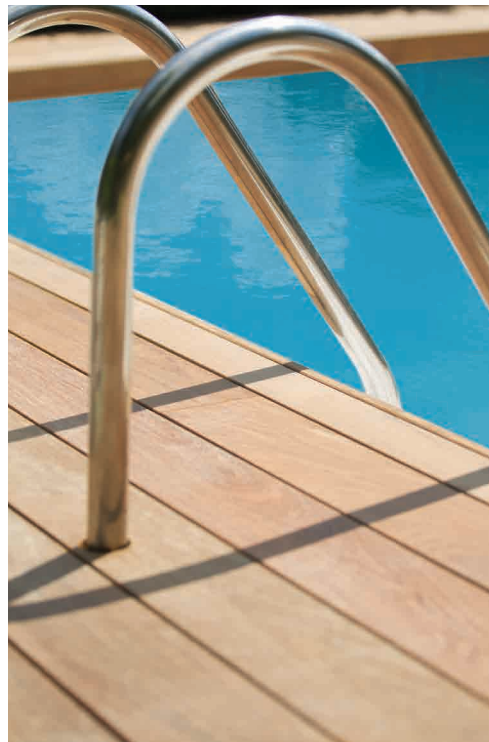

WOODEN PLUGS

BENEFITS

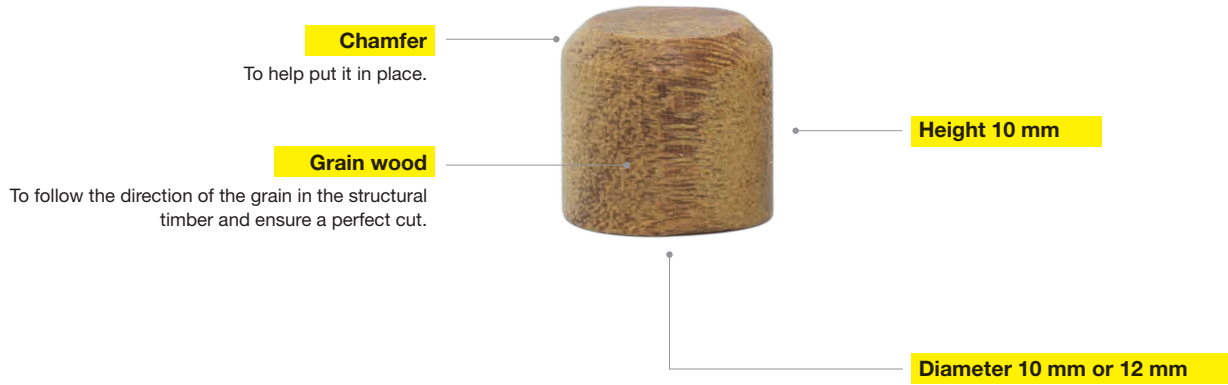

Various species available

A wide range of plugs in exotic, resinous or treated timbers is available, for a perfect match with the species of the structure to be produced and ensure an exceptional, top-of-the-range finish.



Ipe



Padouk



Accoya®



Kebony®



Larch



Cumaru



Oak



Merbau



Afromosia



Doussié



Massaranduba



Garapa



Thermo Ash



Chestnut



USE

The NÖVLEK® wooden plugs ensure a perfect, attractive finish for decking, cladding and joinery, with no screws visible.

The plug must be fitted in line with the wood grain, so it follows that of the structure. The chamfer helps insert the plug in place.

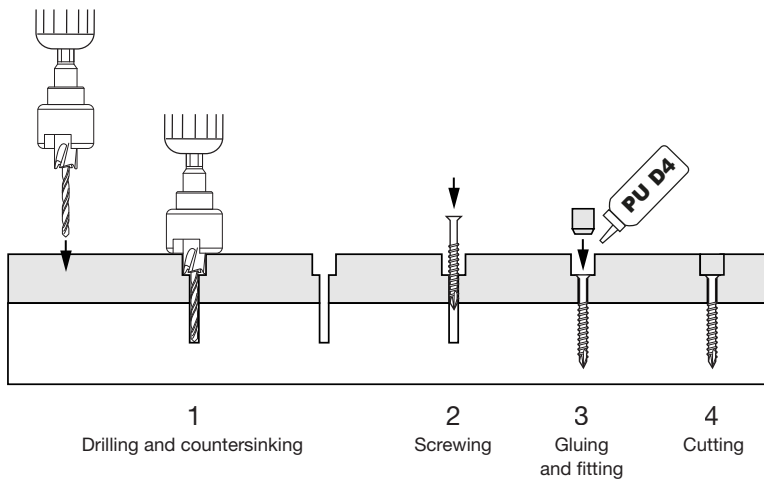

It is advisable to limit the quantity of the PU glue used, applying it only to the end of the plug, so that it does not overflow onto the surface as it expands in drying.



D4 PU glue

The plugs must be glued with a polyurethane (PU) wood glue D4 (NF EN 204).



Leave the plug to protrude 2 to 3 mm

For a perfect finish, with the plugs completely flush, leave the plug some 2 to 3 mm proud of the surface so it can be easily cut back. The ideal drilling depth is 7 mm.



Cutting

To ensure the plug is completely flush with the surface of the structure, it must be cut with a flush cutting saw (flexible blade with Japanese teeth) or a perfectly sharpened wood chisel. The cut must be made in the direction of the wood grain of the plug.



A perfect result

The quality of the insertion and the cut, as well as respect for the installation rules, ensure a perfect, durable result.

As wood is a natural material, variations in colour, veining, grain or lines are possible, depending on the species and source of the timber.



WOODEN PLUGS



Ø 10 mm | 1000 pieces

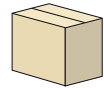

Species	Article code	EAN code	Tub		Box 3 Tubs/Box		Box 12 Tubs/Box	
			Dimensions (mm)	Weight	Dimensions (mm)	Weight	Dimensions (mm)	Weight
Ipe	PLG10-1000-01	5425 03355 411 8	155 x 120 x 125	0,88 kg	365 x 160 x 135	2,77 kg	410 x 410 x 310	11,52 kg
Padouk	PLG10-1000-02	5425 03355 412 5	155 x 120 x 125	0,73 kg	365 x 160 x 135	2,33 kg	410 x 410 x 310	9,76 kg
Accoya®	PLG10-1000-03	5425 03355 413 2	155 x 120 x 125	0,46 kg	365 x 160 x 135	1,51 kg	410 x 410 x 310	6,50 kg
Kebony®	PLG10-1000-04	5425 03355 414 9	155 x 120 x 125	0,56 kg	365 x 160 x 135	1,81 kg	410 x 410 x 310	7,70 kg
Larch	PLG10-1000-05	5425 03355 415 6	155 x 120 x 125	0,60 kg	365 x 160 x 135	1,91 kg	410 x 410 x 310	8,09 kg
Cumaru	PLG10-1000-06	5425 03355 416 3	155 x 120 x 125	0,88 kg	365 x 160 x 135	2,76 kg	410 x 410 x 310	11,50 kg
Merbau	PLG10-1000-07	5425 03355 417 0	155 x 120 x 125	0,76 kg	365 x 160 x 135	2,41 kg	410 x 410 x 310	10,10 kg
Afrormosia	PLG10-1000-08	5425 03355 418 7	155 x 120 x 125	0,72 kg	365 x 160 x 135	2,29 kg	410 x 410 x 310	9,60 kg
Doussié	PLG10-1000-09	5425 03355 419 4	155 x 120 x 125	0,72 kg	365 x 160 x 135	2,27 kg	410 x 410 x 310	9,53 kg
Massaranduba	PLG10-1000-10	5425 03355 440 8	155 x 120 x 125	0,96 kg	365 x 160 x 135	2,99 kg	410 x 410 x 310	12,43 kg
Garapa	PLG10-1000-11	5425 03355 441 5	155 x 120 x 125	0,76 kg	365 x 160 x 135	2,41 kg	410 x 410 x 310	10,08 kg
Thermo Ash	PLG10-1000-12	5425 03355 442 2	155 x 120 x 125	0,61 kg	365 x 160 x 135	1,95 kg	410 x 410 x 310	8,25 kg
Oak	PLG10-1000-13	5425 033 55 443 9	155 x 120 x 125	0,66 kg	365 x 160 x 135	2,11 kg	410 x 410 x 310	8,90 kg
Chestnut	PLG10-1000-14	5425 033 55 444 6	155 x 120 x 125	0,56 kg	365 x 160 x 135	1,81 kg	410 x 410 x 310	7,70 kg



The information shown in this document is given for information purposes and is not contractual. It may be changed at any time without prior notice. All rights reserved ARCHIWOOD sprl.



WOODEN PLUGS



Ø 10 mm | 100 pieces



Species	Article code	EAN code	Box		Box 12 Boxes/Box		Box 36 Boxes/Box	
			Dimensions (mm)	Weight	Dimensions (mm)	Weight	Dimensions (mm)	Weight
Ipe	PLG10-100-01	5425 03355 401 9	58 x 50 x 60	0,08 kg	245 x 190 x 95	1,16 kg	365 x 160 x 135	3,07 kg
Padouk	PLG10-100-02	5425 03355 402 6	58 x 50 x 60	0,07 kg	245 x 190 x 95	0,98 kg	365 x 160 x 135	2,54 kg
Accoya®	PLG10-100-03	5425 03355 403 3	58 x 50 x 60	0,04 kg	245 x 190 x 95	0,66 kg	365 x 160 x 135	1,56 kg
Kebony®	PLG10-100-04	5425 03355 404 0	58 x 50 x 60	0,05 kg	245 x 190 x 95	0,78 kg	365 x 160 x 135	1,92 kg
Larch	PLG10-100-05	5425 03355 405 7	58 x 50 x 60	0,05 kg	245 x 190 x 95	0,82 kg	365 x 160 x 135	2,04 kg
Cumaru	PLG10-100-06	5425 03355 406 4	58 x 50 x 60	0,08 kg	245 x 190 x 95	1,16 kg	365 x 160 x 135	3,08 kg
Merbau	PLG10-100-07	5425 03355 407 1	58 x 50 x 60	0,07 kg	245 x 190 x 95	1,02 kg	365 x 160 x 135	2,64 kg
Afrormosia	PLG10-100-08	5425 03355 408 8	58 x 50 x 60	0,07 kg	245 x 190 x 95	0,97 kg	365 x 160 x 135	2,49 kg
Doussié	PLG10-100-09	5425 03355 409 5	58 x 50 x 60	0,07 kg	245 x 190 x 95	0,96 kg	365 x 160 x 135	2,47 kg
Massaranduba	PLG10-100-10	5425 03355 430 9	58 x 50 x 60	0,09 kg	245 x 190 x 95	1,25 kg	365 x 160 x 135	3,34 kg
Garapa	PLG10-100-11	5425 03355 431 6	58 x 50 x 60	0,07 kg	245 x 190 x 95	1,02 kg	365 x 160 x 135	2,64 kg
Thermo Ash	PLG10-100-12	5425 03355 432 3	58 x 50 x 60	0,05 kg	245 x 190 x 95	0,83 kg	365 x 160 x 135	2,09 kg
Oak	PLG10-100-13	5425 033 55 433 0	58 x 50 x 60	0,06 kg	245 x 190 x 95	0,90 kg	365 x 160 x 135	2,28 kg
Chestnut	PLG10-100-14	5425 033 55 434 7	58 x 50 x 60	0,05 kg	245 x 190 x 95	0,78 kg	365 x 160 x 135	1,92 kg



WOODEN PLUGS



Ipe



Padouk



Oak



New!
Ø 12 mm

Ø 12 mm | 700 pieces



Tub



Box
3 Tubs/Box



Box
12 Tubs/Box

Species	Article code	EAN code	Tub		Box		Box	
			Dimensions (mm)	Weight	Dimensions (mm)	Weight	Dimensions (mm)	Weight
Ipe	PLG12-700-01	5425 03355 480 4	155 x 120 x 125	0,92 kg	365 x 160 x 135	2,89 kg	410 x 410 x 310	12,00 kg
Padouk	PLG12-700-02	5425 03355 481 1	155 x 120 x 125	0,76 kg	365 x 160 x 135	2,42 kg	410 x 410 x 310	10,12 kg
Oak	PLG12-700-13	5425 03355 482 8	155 x 120 x 125	0,70 kg	365 x 160 x 135	2,23 kg	410 x 410 x 310	9,38 kg



WOODEN PLUGS



Ipe



Padouk



Oak



New!
Ø 12 mm

Ø 12 mm | 75 pieces



Box



Box
12 Boxes/Box



Box
36 Boxes/Box

Species	Article code	EAN code	Box		Box 12 Boxes/Box		Box 36 Boxes/Box	
			Dimensions (mm)	Weight	Dimensions (mm)	Weight	Dimensions (mm)	Weight
Ipe	PLG12-075-01	5425 03355 460 6	58 x 50 x 60	0,09 kg	245 x 190 x 95	1,28 kg	365 x 160 x 135	3,43 kg
Padouk	PLG12-075-02	5425 03355 461 3	58 x 50 x 60	0,08 kg	245 x 190 x 95	1,16 kg	365 x 160 x 135	3,08 kg
Oak	PLG12-075-13	5425 03355 462 0	58 x 50 x 60	0,07 kg	245 x 190 x 95	1,02 kg	365 x 160 x 135	2,64 kg







Merchandising and POS



PLANOGRAMS

EXAMPLES OF SHELF LAYOUT

NÖVLEK® can provide its customers with a wide selection of planograms that make efficient use of the available space and offer maximum visual impact. They are also a great tool for making the work of the staff in charge of arranging the products easier and ensuring uniform shelf layout and presentation of NÖVLEK® products.





Full programme available on request



DISPLAY UNITS AND POINTS OF SALE

WOODEN DISPLAY RACKS



MODELS



DISPLAYS



SAMPLES



PALLET DISPLAY BOX



CUBE TOTEM DISPLAY



SHELF DIVIDERS



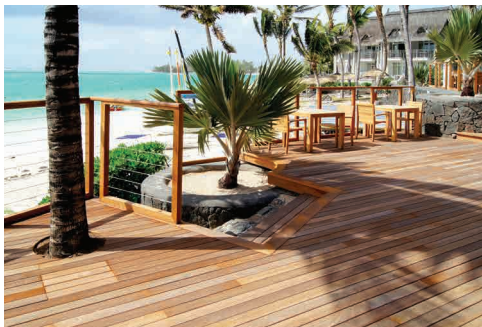
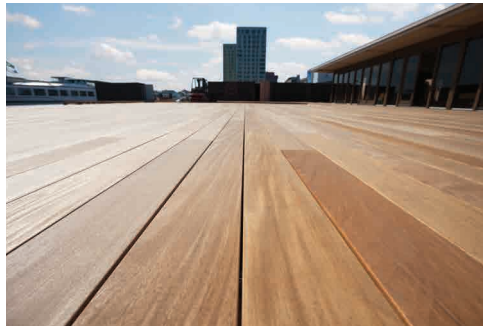
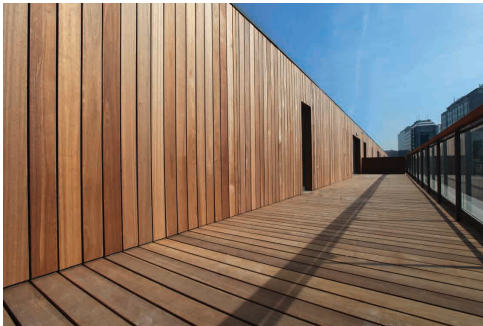
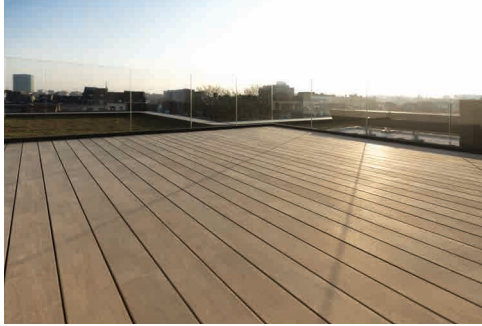

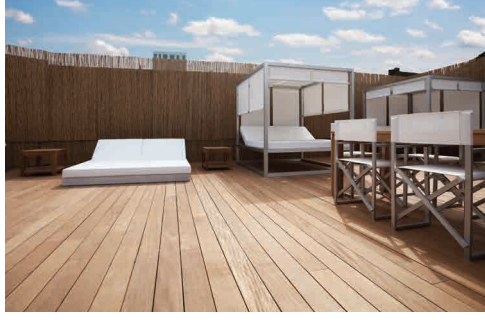
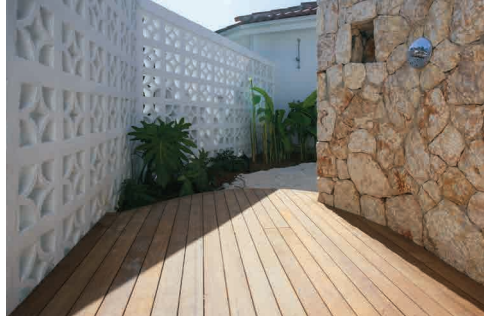



Növlek[®], the brand that guarantees the **satisfaction** and **professionalism** you deserve: tried and tested products, easy to use, no compromise on quality and safety, perfect, long-lasting results and customised, personal service!



STANDARD TERMS AND CONDITIONS OF SALE

The Customer is deemed to have read and understood these standard terms and conditions of sale. All orders imply the Customer's full acceptance of said terms and conditions.

1. DEFINITIONS

Customer: Person who purchases Products | Product: Any Service supplied, materials sold, assembly or construction stipulated in the Order Confirmation | Price: Selling price that appears on the Order Confirmation | Order Confirmation: Written acceptance of the order.

2. SCOPE OF APPLICATION

These standard terms and conditions of sale shall govern all customer relations between ARCHWOOD and its Customers. By submitting a purchase order, the Customer agrees to these standard terms and conditions and acknowledges that they are enforceable. All other standard terms and conditions shall not be valid. No amendments or exemptions to these standard terms and conditions shall be made without ARCHWOOD's prior written consent. Any contract entered into/carried out by ARCHWOOD with Customers who have their own standard terms and conditions shall not imply ARCHWOOD's acceptance of the co-contractor's standard terms and conditions.

3. OFFERS, ORDERS AND ORDER CONFIRMATIONS

Any Product offers made by ARCHWOOD are for informational purposes only. Offers shall generally be valid for one month following the offer date. To be deemed official, purchase orders must be submitted by mail, e-mail or fax. The contract shall be effective when ARCHWOOD has signed and returned the order ("Order Confirmation") by mail, e-mail or fax.

The Customer shall verify the Order Confirmation. The Customer shall notify ARCHWOOD in writing of any errors in the Order Confirmation within 24 hours of receiving it. Failing that, the Order Confirmation shall be deemed to indisputably and accurately reflect the Customer's wishes and the Contract shall be validly entered into according to the terms of the Order Confirmation.

4. PRICES

Prices stated in offers, purchase orders, Order Confirmations and invoices do not include charges, duties and taxes. For example, the Customer shall be liable for value-added tax at the rate in effect on the invoice date, transportation and freight, as well as insurance and customs duties.

Prices are based on business conditions on the offer date, the purchase order, Order Confirmation or Invoice as applicable (for example: 1 product = €10.00; an order for 10 products = €100.00) and may be modified in the event of changes in business conditions that are unfavourable to ARCHWOOD (in our example: 1 product would then cost €13.00; and the price for an order of 10 products would increase to €130.00). In this instance, it is expressly agreed that the Customer may reduce the number of Products ordered without, however, the invoice amount being reduced (in our example: order reduced to 8 products x €13.00 = €104.00). Under these circumstances, a change in price shall in no way lead to an order cancellation.

5. PAYMENT TERMS

- Invoices guaranteed by the factor: In principle, invoices shall be payable to the factor, according to the terms and conditions set by the factor.

- Invoices not guaranteed by the factor: Failing that, invoices shall be fully paid in cash, before the Customer picks up the merchandise or it is shipped to the Customer.

Should the Customer have not paid the invoice within 15 (fifteen) days of the invoice date or not taken delivery of the Products, ARCHWOOD may allocate Products in inventory initially reserved to fill the Customer's order to another customer. This could lead to additional delivery delays for the Customer even after paying the invoice.

- Invoices not guaranteed by the factor or not paid in cash by the Customer before delivery: In cases where the Customer takes possession of the Products before having paid the invoice in full and the payment is not covered by the factor, the invoice shall be fully paid in cash. Compound interest of 12% per annum shall be applicable immediately as a matter of right, without any justification or prior notice required. In the event of non-payment within 15 (fifteen) days of the invoice date, a fifteen percent (15%) surcharge shall also be applied to the invoice amount (minimum of one hundred and twenty-five (125) euros for handling and administration costs).

In the event of non-payment of an invoice, ARCHWOOD may cancel the Confirmation of another Order placed by the Customer. In this instance, the Customer shall be deemed to have cancelled the order, which shall entitle ARCHWOOD to a lump-sum compensation corresponding to the deposit amount or, failing that, 30% of the order amount.

Payments are always applied to the oldest debt and, in order of priority, the interest on overdue payments, charges or possible compensation amounts.

6. DELIVERY

- Delivery time: Unless stipulated otherwise in the Order Confirmation, the delivery time stated in the Order Confirmation is for informational purposes only. Late deliveries shall not lead to the cancellation of the contract or payment of damages and interest. Delivery time is calculated as of the Order Confirmation date.

- Delivery or pick-up location: Unless stipulated otherwise, the delivery or pick-up location shall be at the ARCHWOOD warehouses.

Should ARCHWOOD agree to organize the transportation of Products to a destination selected by the Customer, goods shall be transported on behalf of and in the Customer's name. Transportation shall be charged to the Customer and shall be at owner's risk.

Under no circumstances shall ARCHWOOD be liable on account of, due to or upon transportation of the Products.

Should Products not be picked up or if delivery is refused, Products stored in our warehouses shall be at the Customer's expense and risk upon written notice to the Customer.

- Delivery verification: The Customer shall verify the delivery. The Customer shall advise ARCHWOOD of any delivery errors immediately upon receiving the Products and report them in writing on the Deliver Order supplied by the carrier. The Customer shall inform ARCHWOOD in writing within 24 hours and provide proof of the errors (Delivery Order, photos, etc.). Failing that, the delivery shall be deemed to indisputably and accurately reflect the Customer's wishes upon signing the contract.

- Property – Risks

i. Invoice guaranteed by the factor: The transfer of ownership of the Products and related risks shall take place on the date the invoice is paid by the Customer. From that moment on, any Products that the Customer has not picked up from ARCHWOOD's warehouses shall be at the Customer's risk.

ii. Invoice not guaranteed by the factor, but paid in cash by the Customer before delivery: The transfer of ownership of Products and related risks shall take place on the date the invoice is paid in full by the Customer.

iii. Invoice not guaranteed by the factor or paid in cash by the Customer before delivery: The transfer of ownership of Products and related risks shall take place on the date the invoice is paid in full by the Customer.

7. TERMINATION

Should the Customer cancel an order, the Customer shall be obliged to compensate ARCHWOOD on its own initiative for an amount corresponding to the deposit made or, failing that, 30% of the order amount without prejudice to any damages for a specific damage. ARCHWOOD may unilaterally terminate this contract at its sole discretion without prejudice to its other rights, should (i) the Customer fail to pay amounts when due, (ii) there be a change in the Customer's situation (death, discontinuance of business, etc.) and/or (iv) bankruptcy or arrangement with creditors by the Customer.

8. TITLE RETENTION CLAUSE

ARCHWOOD shall retain ownership of Products until they are paid in full. The Customer shall be liable for all risks. The Customer shall not pledge or in any way charge by way of security Products before payment in full is made. In the event of seizure by a third party, the Customer shall notify us immediately under penalty of potential damages. Should Products belonging to ARCHWOOD be resold, even if altered, the Customer shall immediately transfer all accounts receivable resulting from their resale to ARCHWOOD. The name of the third-party purchaser shall be provided to ARCHWOOD upon simple request. ARCHWOOD reserves the right to notify the purchaser about this title retention clause and to consequently request that the purchaser pay ARCHWOOD directly.

9. GUARANTEES

ARCHWOOD guarantees the quality of its Products. However, subject to any legislation to the contrary, the Customer shall – under penalty of foreclosure – file any claim regarding the quality of Products within 48 hours of delivery. Beyond that 48-hour period, no claims or disputes of any kind shall be admissible. Moreover, ARCHWOOD shall not be held to any guarantees if the Customer or a third party under its responsibility remanufactures, alters or modifies Products, or for the consequences of defects in third-party products. Furthermore, ARCHWOOD shall not be liable in the following instances: normal wear and tear, abnormal Product use, failure to follow Product instructions, Product misuse, extreme environmental conditions, etc. Should a claim be made against the ARCHWOOD guarantee, ARCHWOOD shall only be liable for the replacement, with all due dispatch and as little disruption to the Customer as possible, of the defective Product by a Product of equal or higher specifications than the Product described in the Order Confirmation, thereby excluding any other form of compensation. Should it prove impossible to find a Product replacement or repair the defect, ARCHWOOD shall not be liable for an amount greater than the product Price.

10. FORCE MAJEURE

ARCHWOOD shall not be liable for the consequences of Force majeure, which can be defined for the purposes of this contract as any circumstances beyond the reasonable control of ARCHWOOD.

11. LEGAL PROVISIONS

11.1 This contract is governed and construed in accordance with the laws of Belgium. It is agreed that the obligations under the contract entered into by ARCHWOOD and the Customer are established in Brussels and shall be carried out there. To the fullest extent applicable by law, the Courts and tribunals of Brussels shall have sole jurisdiction over this contract. However, ARCHWOOD reserves the right of recourse through the Courts and tribunals of the Customer's domicile/head office.

11.2 The invalidity of a provision shall not lead to the invalidity of the entire contract, but solely to the provision's replacement by a provision of comparable effect and scope.

11.3 Any express agreement departing from these standard terms and conditions shall only apply to the specific contract in question and shall not, under any circumstances, be deemed a general provision.



SOLUTIONS FOR TIMBER DECKING AND CLADDING